

Vlastnosti

Přípoj 1	Vnější cylindrický závit BSP
Tvar těsnění 1	Tvar B
Přípoj 2	metrický vnější cylindrický závit
Tvar těsnění 2	Vnitřní kužel 24°
Konstrukce	hrdlové šroubení
Provedení	přímé
Norma	DIN 2353 ISO 8434-1
Obsah dodávky	hrdlo s přesuvnou maticí a zářezným kroužkem
Materiál	mosaz

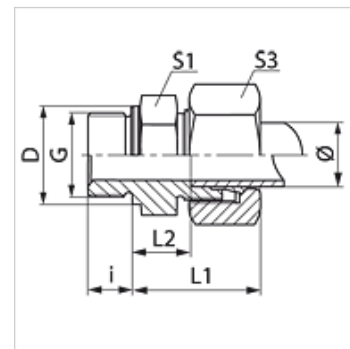

Upozornění

Upozornění k montáži, vestavbě, tlakovému zatížení a povoleným provozním teplotám si prosím vyhledejte v technických dokumentacích fitinkových šroubení.

Výrobek

Označení	Typová řada	Provozní tlak v barech	Vnější Ø trubky (mm)	G	D (mm)	i (mm)	L1 (mm)	L2 (mm)	S1	S3
VR NW 04 HL MG	L	PN 200	6	G 1/8" -28	14	8	23,0	8,5	14	14
VR NW 04 HL 1/4 MG	L	PN 200	6	G 1/4" -19	18	12	24,5	10,0	19	14
VR NW 04 HL 3/8 MG	L	PN 200	6	G 3/8" -19	22	12	26,0	11,5	22	14
VR NW 04 HL 1/2 MG	L	PN 200	6	G 1/2" -14	26	14	26,5	12,0	27	14
VR NW 06 HL 1/8 MG	L	PN 200	8	G 1/8" -28	14	8	24,0	9,0	14	17
VR NW 06 HL MG	L	PN 200	8	G 1/4" -19	18	12	25,0	10,0	19	17
VR NW 06 HL 3/8 MG	L	PN 200	8	G 3/8" -19	22	12	26,5	11,5	22	17
VR NW 06 HL 1/2 MG	L	PN 200	8	G 1/2" -14	26	14	27,0	12,0	27	17
VR NW 08 HL MG	L	PN 200	10	G 1/4" -19	18	12	26,0	11,0	19	19
VR NW 08 HL 3/8 MG	L	PN 200	10	G 3/8" -19	22	12	27,5	12,5	22	19
VR NW 08 HL 1/2 MG	L	PN 200	10	G 1/2" -14	26	14	28,0	13,0	27	19
VR NW 10 HL 1/4 MG	L	PN 200	12	G 1/4" -19	18	12	26,5	12,0	19	22
VR NW 10 HL MG	L	PN 200	12	G 3/8" -19	22	12	27,0	12,5	22	22
VR NW 10 HL 1/2 MG	L	PN 200	12	G 1/2" -14	26	14	27,5	13,0	27	22
VR NW 13 HL 3/8 MG	L	PN 160	15	G 3/8" -19	22	12	29,0	14,0	24	27
VR NW 13 HL MG	L	PN 160	15	G 1/2" -14	26	14	29,0	14,0	27	27
VR NW 16 HL MG	L	PN 160	18	G 1/2" -14	26	14	31,0	14,5	27	32
VR NW 20 HL 1/2 MG	L	PN 100	22	G 1/2" -14	26	14	33,0	16,5	32	36
VR NW 20 HL MG	L	PN 100	22	G 3/4" -14	32	16	33,0	16,5	32	36
VR NW 25 HL MG	L	PN 100	28	G 1" -11	39	18	34,0	17,5	41	41
VR NW 32 HL MG	L	PN 100	35	G 1.1/4" -11	49	20	39,0	17,5	50	50
VR NW 40 HL MG	L	PN 100	42	G 1.1/2" -11	55	22	42,0	19,0	55	60
VR NW 03 HS MG	S	PN 250	6	G 1/4" -19	18	12	28,0	13,0	19	17
VR NW 04 HS MG	S	PN 250	8	G 1/4" -19	18	12	30,0	15,0	19	19
VR NW 04 HS 1/2 MG	S	PN 250	8	G 1/2" -14	26	14	34,0	17,5	27	19
VR NW 06 HS 1/4 MG	S	PN 250	10	G 1/4" -19	18	12	30,5	14,5	22	22
VR NW 06 HS MG	S	PN 250	10	G 3/8" -19	22	12	31,0	15,0	22	22
VR NW 06 HS 1/2 MG	S	PN 250	10	G 1/2" -14	26	14	33,5	17,5	27	22
VR NW 08 HS MG	S	PN 250	12	G 3/8" -19	22	12	33,0	17,0	22	24
VR NW 08 HS 1/2 MG	S	PN 250	12	G 1/2" -14	26	14	33,5	17,5	27	24
VR NW 10 HS MG	S	PN 250	14	G 1/2" -14	26	14	37,0	19,0	27	27
VR NW 13 HS MG	S	PN 250	16	G 1/2" -14	26	14	37,0	18,5	27	30
VR NW 16 HS 1/2 MG	S	PN 250	20	G 1/2" -14	26	14	44,0	22,5	32	36
VR NW 16 HS MG	S	PN 250	20	G 3/4" -14	39	18	44,0	22,5	32	36
VR NW 20 HS 3/4 MG	S	PN 160	25	G 3/4" -14	32	16	47,0	23,0	41	46
VR NW 20 HS MG	S	PN 160	25	G 1" -11	39	18	47,0	23,0	41	46
VR NW 25 HS MG	S	PN 100	30	G 1.1/4" -11	49	20	50,0	23,5	50	50
VR NW 32 HS MG	S	PN 100	38	G 1.1/2" -11	55	22	57,0	26,0	55	60

typová řada: LL = velmi lehká L = lehká S = robustní - PN = nominální tlak PB = max. provozní tlak - Ø = vnější průměr trubky

Varianty produktu

VR Šroubení k zašroubování, Ocel



