

# G AN HN

Hrdlo k zašroubování

**HANSA FLEX**

## Vlastnosti

<b>Přípoj 1</b>	Závit pro matice NPT (NPSM)
<b>Tvar těsnění 1</b>	Vnější kužel 60°
<b>Přípoj 2</b>	Vnější závit NPT
<b>Tvar těsnění 2</b>	s těsněním na závit
<b>Konstrukce</b>	Hrdlo k zašroubování
<b>Provedení</b>	přímé
<b>Materiál</b>	Ocel
<b>Povrchová ochrana</b>	galvanicky potažený

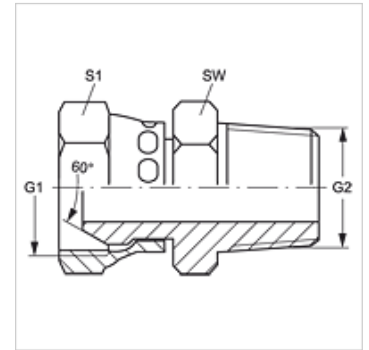

## Výrobek

Označení	G1	G2	SW (mm)	S1
<b>G AN 02 HN</b>	1/8" -27 NPT	1/8" -27 NPT	14	14
<b>G AN 04 HN</b>	1/4" -18 NPT	1/4" -18 NPT	18	18
<b>G AN 04 HN 02</b>	1/4" -18 NPT	1/8" -27 NPT	16	18
<b>G AN 04 HN 06</b>	1/4" -18 NPT	3/8" -18 NPT	18	18
<b>G AN 06 HN</b>	3/8" -18 NPT	3/8" -18 NPT	22	22
<b>G AN 06 HN 04</b>	3/8" -18 NPT	1/4" -18 NPT	21	22
<b>G AN 06 HN 08</b>	3/8" -18 NPT	1/2" -14 NPT	22	22
<b>G AN 08 HN</b>	1/2" -14 NPT	1/2" -14 NPT	25	25
<b>G AN 08 HN 04</b>	1/2" -14 NPT	1/4" -18 NPT	24	25
<b>G AN 08 HN 06</b>	1/2" -14 NPT	3/8" -18 NPT	24	25
<b>G AN 08 HN 12</b>	1/2" -14 NPT	3/4" -14 NPT	29	25
<b>G AN 12 HN</b>	3/4" -14 NPT	3/4" -14 NPT	32	32
<b>G AN 12 HN 08</b>	3/4" -14 NPT	1/2" -14 NPT	32	32
<b>G AN 12 HN 16</b>	3/4" -14 NPT	1" -11,5 NPT	35	38
<b>G AN 16 HN</b>	1" -11,5 NPT	1" -11,5 NPT	38	38
<b>G AN 16 HN 12</b>	1" -11,5 NPT	3/4" -14 NPT	38	38
<b>G AN 20 HN</b>	1.1/4" -11,5 NPT	1.1/4" -11,5 NPT	48	48
<b>G AN 24 HN 16</b>	1.1/2" -11,5 NPT	1" -11,5 NPT	45	54
<b>G AN 24 HN</b>	1.1/2" -11,5 NPT	1.1/2" -11,5 NPT	54	54
<b>G AN 32 HN</b>	2" -11,5 NPT	2" -11,5 NPT	67	67

SW, S1, S2 = otvor klíče