

GE HN IR VA

Hrdlo k zašroubování

HANSA FLEX

Vlastnosti

Přípoj 1	Vnější závit NPT
Tvar těsnění 1	s těsněním na závit
Přípoj 2	Vnitřní závit BSP, cylindrický
Tvar těsnění 2	plošně těsnící
Konstrukce	Hrdlo k zašroubování
Provedení	přímé
Materiál	Ušlechtilá ocel

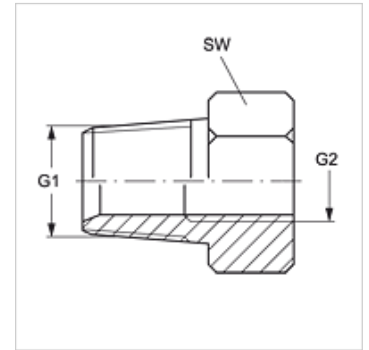

Výrobek

Označení	G1	G2	SW (mm)
GE HN 02 IR VA	1/8" -27 NPT	G 1/8" -28	14
GE HN 02 IR 04 VA	1/8" -27 NPT	G 1/4" -19	19
GE HN 04 IR 02 VA	1/4" -18 NPT	G 1/8" -28	14
GE HN 04 IR VA	1/4" -18 NPT	G 1/4" -19	19
GE HN 04 IR 06 VA	1/4" -18 NPT	G 3/8" -19	24
GE HN 04 IR 08 VA	1/4" -18 NPT	G 1/2" -14	27
GE HN 06 IR 04 VA	3/8" -18 NPT	G 1/4" -19	19
GE HN 06 IR VA	3/8" -18 NPT	G 3/8" -19	24
GE HN 06 IR 08 VA	3/8" -18 NPT	G 1/2" -14	27
GE HN 08 IR 04 VA	1/2" -14 NPT	G 1/4" -19	24
GE HN 08 IR 06 VA	1/2" -14 NPT	G 3/8" -19	24
GE HN 08 IR VA	1/2" -14 NPT	G 1/2" -14	27
GE HN 08 IR 12 VA	1/2" -14 NPT	G 3/4" -14	32
GE HN 12 IR 06 VA	3/4" -14 NPT	G 3/8" -19	27
GE HN 12 IR 08 VA	3/4" -14 NPT	G 1/2" -14	27
GE HN 12 IR VA	3/4" -14 NPT	G 3/4" -14	32
GE HN 12 IR 16 VA	3/4" -14 NPT	G 1" -11	41
GE HN 16 IR 08 VA	1" -11,5 NPT	G 1/2" -14	36
GE HN 16 IR 12VA	1" -11,5 NPT	G 3/4" -14	36
GE HN 16 IR VA	1" -11,5 NPT	G 1" -11	41
GE HN 20 IR VA	1.1/4" -11,5 NPT	G 1.1/4" -11	55
GE HN 24 IR VA	1.1/2" -11,5 NPT	G 1.1/2" -11	55

SW = otvor klíče