

Vlastnosti

Přípoj 1 Vnitřní závity UN/UNF

Tvar těsnění 1 Vnitřní kužel 74°

Přípoj 2 Vnitřní závít BSP, cylindrický

Tvar těsnění 2 plošně těsnící

Konstrukce Přesuvná matice

Materiál Ocel

Povrchová ochrana galvanicky potažený

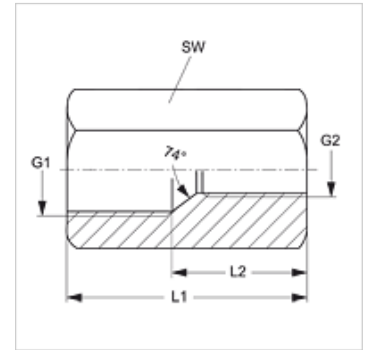

Výrobek

Označení	G1	G2	L1 (mm)	L2 (mm)	SW (mm)
UEM AJ 04 IR	7/16" -20 UNF	G 1/4" -19	29	-	19
UEM AJ 05 IR 04	1/2" -20 UNF	G 1/4" -19	29	-	19
UEM AJ 06 IR 04	9/16" -18 UNF	G 1/4" -19	29	-	19
UEM AJ 06 IR	9/16" -18 UNF	G 3/8" -19	29	-	19
UEM AJ 08 IR 04	3/4" -16 UNF	G 1/4" -19	32	-	22
UEM AJ 08 IR	3/4" -16 UNF	G 1/2" -14	32	-	22
UEM AJ 10 IR 04	7/8" -14 UNF	G 1/4" -19	32	-	27
UEM AJ 10 IR 08	7/8" -14 UNF	G 1/2" -14	32	-	27
UEM AJ 12 IR 04	1.1/16" -12 UN	G 1/4" -19	-	13	32
UEM AJ 12 IR	1.1/16" -12 UN	G 3/4" -14	-	13	32
UEM AJ 14 IR 04	1.3/16" -12 UN	G 1/4" -19	-	19	36
UEM AJ 16 IR 04	1.5/16" -12 UN	G 1/4" -19	-	20	41
UEM AJ 16 IR	1.5/16" -12 UN	G 1" -11	-	20	41
UEM AJ 20 IR 04	1.5/8" -12 UN	G 1/4" -19	-	20	50
UEM AJ 24 IR 04	1.7/8" -12 UN	G 1/4" -19	-	24	60

SW, S1, S2 = otvor klíče