

### Vlastnosti

<b>Použití</b>	Rozvody chladicích kapalin a maziv pro obrábění kovů.
<b>Provedení</b>	Ocelový šroubovitě navinutý nosný drát s vnitřní hadicí z PVC es. Šroubovací čepy as. Vypouštěcí tryska z oceli Povrch poniklovany
<b>Vlastnosti</b>	Absolutně těsný lze ohýbat rukou téměř do jakékoli polohy stabilní odolný proti olejům, tukům atd.

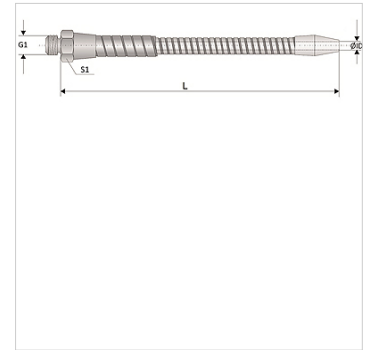

### Upozornění k objednávkám

Jiné rozměry na objednávku

### Výrobek

Označení	G1	ID (mm)	S1 (mm)	Jmenovitá délka (+/-5 mm)
NIAG 1/8-200	R 1/8"	8,0	15,0	200
NIAG 1/8-250	R 1/8"	8,0	15,0	250
NIAG 1/8-320	R 1/8"	8,0	15,0	320
NIAG 1/8-400	R 1/8"	8,0	15,0	400
NIAG 1/8-500	R 1/8"	8,0	15,0	500
NIAG 1/8-630	R 1/8"	8,0	15,0	630
NIAG 1/8-800	R 1/8"	8,0	15,0	800
NIAG 1/4-200	R 1/4"	10,0	19,0	200
NIAG 1/4-250	R 1/4"	10,0	19,0	250
NIAG 1/4-320	R 1/4"	10,0	19,0	320
NIAG 1/4-400	R 1/4"	10,0	19,0	400
NIAG 1/4-500	R 1/4"	10,0	19,0	500
NIAG 1/4-630	R 1/4"	10,0	19,0	630
NIAG 1/4-800	R 1/4"	10,0	19,0	800
NIAG 3/8-250	R 3/8"	10,0	24,0	250
NIAG 3/8-300	R 3/8"	10,0	24,0	300
NIAG 3/8-320	R 3/8"	10,0	24,0	320
NIAG 3/8-400	R 3/8"	10,0	24,0	400
NIAG 3/8-500	R 3/8"	10,0	24,0	500
NIAG 3/8-630	R 3/8"	10,0	24,0	630
NIAG 3/8-800	R 3/8"	10,0	24,0	800
NIAG 1/2-250	R 1/2"	12,0	27,0	250
NIAG 1/2-320	R 1/2"	12,0	27,0	320
NIAG 1/2-400	R 1/2"	12,0	27,0	400
NIAG 1/2-500	R 1/2"	12,0	27,0	500
NIAG 1/2-630	R 1/2"	12,0	27,0	630
NIAG 1/2-800	R 1/2"	12,0	27,0	800