

# PN HN VA

## Lisovaná vsuvka, AGN

### Vlastnosti

<b>Oblast použití</b>	lisovaná vsuvka pro hadice HD 100 až HD 400, KP, TE
<b>Přípoj 1</b>	Vnější závit NPT
<b>Tvar těsnění 1</b>	Těsnící závit, přídatný vnitřní kužel 60°
<b>Zkratka</b>	AGN
<b>Materiál</b>	Ušlechtilá ocel

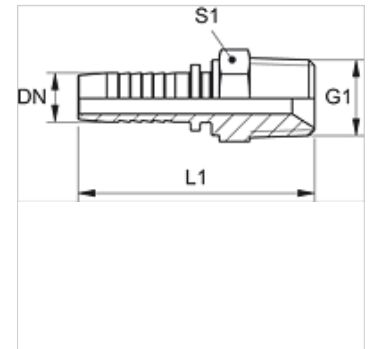

### Upozornění

Vhodnou objímku zvolte prosím podle typu hadice.

### Výrobek

Označení	DN	Velikost	palce	Provozní tlak (bar)	G1	S1
PN 06 HN 02 VA	6	4	1/4"	345,0	1/8" -27 NPT	14
PN 06 HN VA	6	4	1/4"	345,0	1/4" -18 NPT	14
PN 06 HN 10 VA	6	4	1/4"	275,0	3/8" -18 NPT	19
PN 08 HN 06 VA	8	5	5/16"	345,0	1/4" -18 NPT	-
PN 08 HN 10 VA	8	5	5/16"	275,0	3/8" -18 NPT	19
PN 10 HN 06 VA	10	6	3/8"	275,0	1/4" -18 NPT	-
PN 10 HN VA	10	6	3/8"	275,0	3/8" -18 NPT	19
PN 10 HN 13 VA	10	6	3/8"	240,0	1/2" -14 NPT	22
PN 13 HN 10 VA	12	8	1/2"	240,0	3/8" -18 NPT	19
PN 13 HN VA	12	8	1/2"	240,0	1/2" -14 NPT	22
PN 13 HN 20 VA	12	8	1/2"	210,0	3/4" -14 NPT	27
PN 16 HN 13 VA	16	10	5/8"	210,0	1/2" -14 NPT	-
PN 16 HN 20 VA	16	10	5/8"	210,0	3/4" -14 NPT	27
PN 20 HN 13 VA	19	12	3/4"	210,0	1/2" -14 NPT	-
PN 20 HN VA	19	12	3/4"	210,0	3/4" -14 NPT	27
PN 20 HN 25 VA	19	12	3/4"	170,0	1" -11,5 NPT	36
PN 25 HN 20 VA	25	16	1"	170,0	3/4" -14 NPT	-
PN 25 HN VA	25	16	1"	170,0	1" -11,5 NPT	36
PN 25 HN 32 VA	25	16	1"	150,0	1.1/4" -11,5 NPT	-
PN 32 HN VA	31	20	1.1/4"	150,0	1.1/4" -11,5 NPT	46
PN 32 HN 40 VA	31	20	1.1/4"	140,0	1.1/2" -11,5 NPT	-
PN 40 HN VA	38	24	1.1/2"	140,0	1.1/2" -11,5 NPT	50
PN 50 HN VA	51	32	2"	140,0	2" -11,5 NPT	65

### Varianty produktu

PN HN Lisovaná vsuvka, AGN, Ocel