

# PN SF

Lisovaná vsuvka, SFL

**HANSA FLEX**

## Vlastnosti

<b>Oblast použití</b>	lisovaná vsuvka pro hadice HD 100 až HD 400, KP, TE
<b>Přípoj 1</b>	Přírubová přípojka SAE 3000 PSI
<b>Tvar těsnění 1</b>	plošně těsnící s O-kroužkem SF
<b>Zkratka</b>	SFL
<b>Norma</b>	SAE J518 ISO 6162-1
<b>Materiál</b>	Ocel
<b>Povrchová ochrana</b>	galvanicky potažený

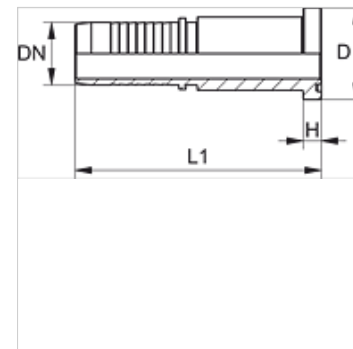

## Upozornění

Vhodnou objímku zvolte prosím podle typu hadice.

## Výrobek

Označení	DN	Velikost	palce	Velikost příruby	Provozní tlak (bar)	D (mm)	H (mm)	L1 (mm)
PN 13 SF	12	8	1/2"	1/2"	350,0	30,2	6,80	80,5
PN 13 SF 20	12	8	1/2"	3/4"	350,0	38,1	6,80	85,5
PN 16 SF 13	16	10	5/8"	1/2"	350,0	30,2	6,80	85,0
PN 16 SF 20	16	10	5/8"	3/4"	350,0	38,1	6,80	90,0
PN 16 SF 25	16	10	5/8"	1"	320,0	44,4	8,10	97,5
PN 20 SF 13	19	12	3/4"	1/2"	350,0	30,2	6,80	91,0
PN 20 SF	19	12	3/4"	3/4"	350,0	38,1	6,80	96,5
PN 20 SF 25	19	12	3/4"	1"	320,0	44,4	8,10	99,5
PN 25 SF 20	25	16	1"	3/4"	320,0	38,1	6,80	104,5
PN 25 SF	25	16	1"	1"	320,0	44,4	8,10	110,5
PN 25 SF 32	25	16	1"	1.1/4"	280,0	50,8	8,10	113,5
PN 32 SF 25	31	20	1.1/4"	1"	-	44,4	8,10	118,0
PN 32 SF	31	20	1.1/4"	1.1/4"	-	50,8	8,10	125,5
PN 32 SF 40	31	20	1.1/4"	1.1/2"	210,0	60,3	8,10	128,5
PN 40 SF 32	38	24	1.1/2"	1.1/4"	210,0	50,8	8,10	129,0
PN 40 SF	38	24	1.1/2"	1.1/2"	210,0	60,3	8,10	135,0
PN 40 SF 50	38	24	1.1/2"	2"	210,0	71,4	9,60	138,0
PN 50 SF 40	51	32	2"	1.1/2"	210,0	60,3	8,10	149,5
PN 50 SF	51	32	2"	2"	210,0	71,4	9,60	153,0
PN 50 SF 60	51	32	2"	2.1/2"	175,0	84,0	9,60	156,0
PN 60 SF 50	60	40	2.3/8"	2"	175,0	71,4	9,60	155,5
PN 60 SF	60	40	2.3/8"	2.1/2"	175,0	84,1	9,60	158,5
PN 76 SF	76	48	3"	3"	160,0	101,6	9,53	150,0
PN 76 SF 60	76	48	3"	2.1/2"	160,0	84,0	9,53	166,0

## Varianty produktu

PN SF VA Lisovaná vsuvka, SFL, Ušlechtilá ocel