

# T HRO HB

Hrdlo k zašroubování, tvar T

**HANSA FLEX**

## Vlastnosti

<b>Přípoj 1</b>	Vnější cylindrický závit BSP
<b>Tvar těsnění 1</b>	tvar G
<b>Přípoj 2 + 3</b>	Vnější cylindrický závit BSP
<b>Tvar těsnění 2 + 3</b>	Vnitřní kužel 60°
<b>Konstrukce</b>	Hrdlo k zašroubování směrově stavitelné
<b>Provedení</b>	tvar T
<b>Materiál</b>	Ocel
<b>Povrchová ochrana</b>	galvanicky potažený

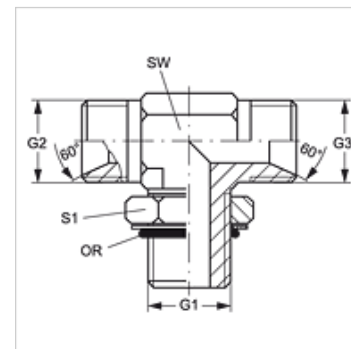

## Výrobek

Označení	G1	G2 + G3	SW (mm)	S1	OR
T HRO 02 HB	G 1/8" -28	G 1/8" -28	11	16	7,65 x 1,78
T HRO 04 HB 02	G 1/4" -19	G 1/8" -28	14	20	10,78 x 2,62
T HRO 04 HB	G 1/4" -19	G 1/4" -19	19	20	10,78 x 2,62
T HRO 04 HB 06	G 1/4" -19	G 3/8" -19	14	20	10,78 x 2,62
T HRO 06 HB 04	G 3/8" -19	G 1/4" -19	19	24	13,94 x 2,62
T HRO 06 HB	G 3/8" -19	G 3/8" -19	19	24	13,94 x 2,62
T HRO 06 HB 08	G 3/8" -19	G 1/2" -14	19	24	13,94 x 2,62
T HRO 08 HB 06	G 1/2" -14	G 3/8" -19	22	28	17,86 x 2,62
T HRO 08 HB	G 1/2" -14	G 1/2" -14	22	28	17,86 x 2,62
T HRO 08 HB 10	G 1/2" -14	G 5/8" -14	22	28	17,86 x 2,62
T HRO 08 HB 12	G 1/2" -14	G 3/4" -14	27	28	17,86 x 2,62
T HRO 12 HB 08	G 3/4" -14	G 1/2" -14	27	35	23,47 x 2,62
T HRO 12 HB	G 3/4" -14	G 3/4" -14	27	35	23,47 x 2,62
T HRO 12 HB 16	G 3/4" -14	G 1" -11	33	35	23,47 x 2,62
T HRO 16 HB 12	G 1" -11	G 3/4" -14	33	43	29,74 x 3,53
T HRO 16 HB	G 1" -11	G 1" -11	33	43	29,74 x 3,53
T HRO 20 HB 16	G 1.1/4" -11	G 1" -11	41	52	37,69 x 3,53
T HRO 20 HB	G 1.1/4" -11	G 1.1/4" -11	41	52	37,69 x 3,53
T HRO 24 HB	G 1.1/2" -11	G 1.1/2" -11	50	58	44,04 x 3,53

SW, S1, S2 = otvor klíče