

Vlastnosti

Konstrukce	Stírací kroužek
Kluzná rychlost max.	4,0 m/s
Teplota min.	-30 °C
Teplota max.	110 °C
Média	minerální oleje
Montáž	stírací kroužek zatlačte do upevňovací drážky
Materiál	Stírací kroužek: PA + MoS2
Použití	Hydraulika

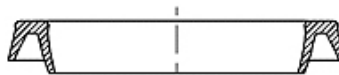

Toleranz / Tolerance			
d	D	L	C
h11	+0,20 0	+0,25 0	+0,10 0

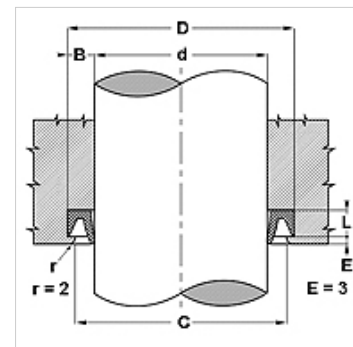

Popis

jednoduchá montáž
 Jednoduché řešení.
 vysoká odolnost proti oděru

Výrobek

Označení	d (mm)	D (mm)	L (mm)	C (mm)
NW 500	12,70	22,22	4,4	20,62
NW 16	16,00	26,00	4,5	24,50
NW 750	19,05	31,75	6,0	30,15
NW 20	20,00	33,00	6,0	31,50
NW 875	22,22	34,92	6,0	33,32
NW 25	25,00	38,00	6,0	36,50
NW 1000	25,40	38,10	6,0	36,50
NW 1125	28,57	41,27	6,0	99,70
NW 1250	31,80	44,45	6,0	72,29
NW 1500	38,10	50,80	6,0	49,20
NW 1750	44,45	57,15	6,0	52,37
NW 50	50,00	63,00	6,0	61,50
NW 2000	50,80	63,50	6,0	61,90
NW 2500	63,50	76,20	6,0	74,60
NW 2750	69,85	82,55	6,0	80,65
NW 70	70,00	83,00	6,0	81,50
NW 3000	76,20	88,90	6,0	87,30