

K-FI REGL PC-BEHÄEL MANO VARIOBLOC

Filter regulators with polycarbonate bowl and pressure gauge

HANSA FLEX

Vlastnosti

Tlak na vstupu	Max. 16 bar (polycarbonate bowl), Max. 20 bar (metal bowl)
Teplota média	max. 50 °C
Teplota okolí	Max. 50 °C (polycarbonate bowl), Max. 80 °C (metal bowl)
Šířka póru ve filtrační vložce	40 µm
Těsnicí materiál	Nitrilkaučuk
Kryt pružiny	POM
Pouzdro	Die-cast zinc
Membrána	NBR
Drain valve	Manual
Měření hodnoty průtoku	At P1 = 10 bar, P2 = 6 bar and pressure drop $\Delta p = 1$ bar

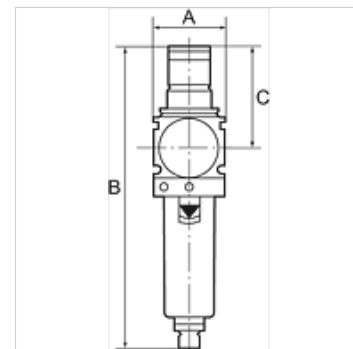

Upozornění

Další údaje na dotaz.

Popis

Reversible diaphragm pressure regulators, independent of inlet pressure, with self-relieving design, combined with a centrifugal separator. The pressure setting can be locked by pushing the knob down. Approved series in modern industrial design, with the following key benefits: Simple handling, Convenient modular assembly thanks to innovative fasteners, Excellent flow values.

Upozornění k objednávkám

Filter regulators are also available with bowl guard or metal bowl. Filter regulators are also available in lockable version. Please ask for more information.

Další informace

Filter regulators are also available with bowl guard or metal bowl. Filter regulators are also available in lockable version. Please ask for more information.

Výrobek

Označení	Závit	Regulační rozsah	Průtok (L/min)	A (mm)	B	C (mm)
K- 07 25 06 85	G 1/4	0.5 - 10 bar	2000	48,0	203,0 mm	68,0
K- 07 25 06 87	G 3/8	0.5 - 10 bar	3000	48,0	203,0 mm	68,0
K- 07 25 06 89	G 1/2	0.5 - 10 bar	5500	70,0	273,0 mm	98,0
K- 07 25 06 91	G 3/4	0.5 - 10 bar	6500	70,0	273,0 mm	98,0
K- 07 25 06 93	G 1	0.5 - 10 bar	6500	124,0	273,0 mm	98,0

Náhradní díly

K-VERSCHLEI-SATZ VARIOBLOC	Set of wearing parts
K-ERSATZBEHÄELTER VARIOBLOC POLY	Spare tank Polycarbonat
K-FILTERELEMENT VARIOBLOC	Filter element
K-ABLASSVENTIL AUTO	Fully-automatic drain valve with Adapter G 1/8