

Eigenschaften

Anschluss 1	metrisches Muttergewinde
Bauart	Überwurfmutter
Norm	DIN 3870
Werkstoff	Edelstahl

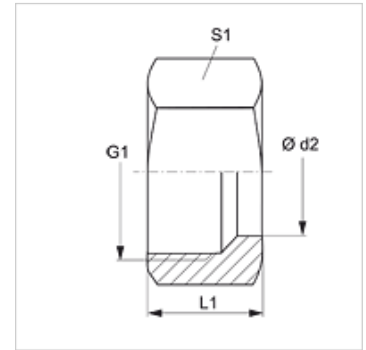
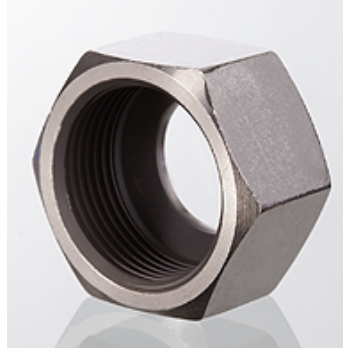

Artikel

Bezeichnung	Baureihe	Ø d2 (mm)	G1	L1 (mm)	S1
UEM 04 LL VA	LL	4	M 8 x 1	11,5	10
UEM 06 LL VA	LL	6	M 10 x 1	12,0	12
UEM 08 LL VA	LL	8	M 12 x 1	12,5	14
UEM NW 04 L VA	L	6	M 12 x 1,5	15,0	14
UEM NW 06 L VA	L	8	M 14 x 1,5	15,0	17
UEM NW 08 L VA	L	10	M 16 x 1,5	16,0	19
UEM NW 10 L VA	L	12	M 18 x 1,5	16,0	22
UEM NW 13 L VA	L	15	M 22 x 1,5	17,5	27
UEM NW 16 L VA	L	18	M 26 x 1,5	18,5	32
UEM NW 20 L VA	L	22	M 30 x 2	20,5	36
UEM NW 25 L VA	L	28	M 36 x 2	21,5	41
UEM NW 32 L VA	L	35	M 45 x 2	24,5	50
UEM NW 40 L VA	L	42	M 52 x 2	24,5	60
UEM NW 03 S VA	S	6	M 14 x 1,5	17,0	17
UEM NW 04 S VA	S	8	M 16 x 1,5	17,0	19
UEM NW 06 S VA	S	10	M 18 x 1,5	18,0	22
UEM NW 08 S VA	S	12	M 20 x 1,5	18,0	24
UEM NW 10 S VA	S	14	M 22 x 1,5	21,0	27
UEM NW 13 S VA	S	16	M 24 x 1,5	21,0	30
UEM NW 16 S VA	S	20	M 30 x 2	24,5	36
UEM NW 20 S VA	S	25	M 36 x 2	27,5	46
UEM NW 25 S VA	S	30	M 42 x 2	29,5	50
UEM NW 32 S VA	S	38	M 52 x 2	33,0	60

Baureihe: LL = Sehr Leicht L = Leicht S = Schwer - PN = Nenndruck PB = max. Betriebsdruck - Ø d2 = Rohraußendurchmesser

Produktvarianten

UEM	Überwurfmutter, Stahl
UEM MG	Überwurfmutter MG, Messing