

W45 AN HN

Einschraub-Stutzen, Winkel 45°

HANSA FLEX

Eigenschaften

Anschluss 1 NPT-Muttergewinde (NPSM)

Dichtform 1 60° Außenkonus

Anschluss 2 NPT-Außengewinde

Dichtform 2 gewindedichtend

Bauart Einschraub-Stutzen

Bauform Winkel 45°

Werkstoff Stahl

Oberfläche galvanisch beschichtet

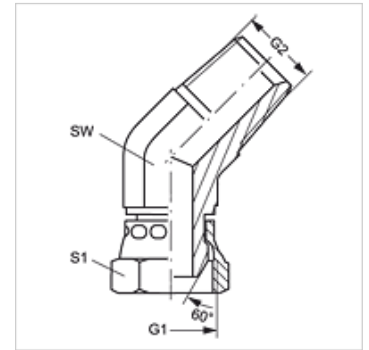

Artikel

Bezeichnung	G1	G2	SW (mm)	S1
W45 AN 02 HN	1/8" -27 NPT	1/8" -27 NPT	11	14
W45 AN 04 HN	1/4" -18 NPT	1/4" -18 NPT	14	18
W45 AN 06 HN	3/8" -18 NPT	3/8" -18 NPT	19	22
W45 AN 06 HN 08	3/8" -18 NPT	1/2" -14 NPT	22	22
W45 AN 08 HN	1/2" -14 NPT	1/2" -14 NPT	22	25
W45 AN 08 HN 12	1/2" -14 NPT	3/4" -14 NPT	27	25
W45 AN 12 HN	3/4" -14 NPT	3/4" -14 NPT	27	32
W45 AN 12 HN 16	3/4" -14 NPT	1" -11,5 NPT	33	32
W45 AN 16 HN 12	1" -11,5 NPT	3/4" -14 NPT	33	38
W45 AN 16 HN	1" -11,5 NPT	1" -11,5 NPT	33	38
W45 AN 20 HN	1.1/4" -11,5 NPT	1.1/4" -11,5 NPT	41	48
W45 AN 24 HN	1.1/2" -11,5 NPT	1.1/2" -11,5 NPT	48	54
W45 AN 32 HN	2" -11,5 NPT	2" -11,5 NPT	64	67

SW, S1, S2 = Schlüsselweite