

W45 O AN

Einschraub-Stutzen, Winkel 45°

HANSA FLEX

Eigenschaften

Anschluss 1	UN/UNF-Außengewinde
Dichtform 1	O-Ring-Abdichtung am Einschraub-Stutzen
Anschluss 2	NPSM-Muttergewinde
Dichtform 2	60° Außenkonus
Bauart	Einschraub-Stutzen richtungseinstellbar
Bauform	Winkel 45°
Werkstoff	Stahl
Oberfläche	galvanisch beschichtet

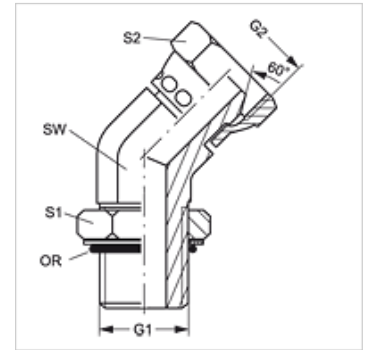

Artikel

Bezeichnung	G1	G2	SW (mm)	S1	S2	OR
W45 O 04 AN	7/16" -20 UNF	1/4" -18 NPT	11	14	18	8,92 x 1,83
W45 O 06 AN 04	9/16" -18 UNF	1/4" -18 NPT	14	22	14	11,90 x 1,98
W45 O 06 AN	9/16" -18 UNF	3/8" -18 NPT	14	18	22	11,90 x 1,98
W45 O 08 AN 06	3/4" -16 UNF	3/8" -18 NPT	19	22	22	16,36 x 2,20
W45 O 08 AN	3/4" -16 UNF	1/2" -14 NPT	19	22	25	16,36 x 2,20
W45 O 08 AN 12	3/4" -16 UNF	3/4" -14 NPT	19	22	32	16,36 x 2,20
W45 O 10 AN 08	7/8" -14 UNF	1/2" -14 NPT	22	25	25	19,18 x 2,46
W45 O 12 AN	1.1/16" -12 UN	3/4" -14 NPT	27	32	32	23,47 x 2,95

SW, S1, S2 = Schlüsselweite