

W90 AJ HJ VA

Aufschraub-Stutzen, Winkel 90°

HANSA FLEX

Eigenschaften

Anschluss 1 UN/UNF-Muttergewinde

Dichtform 1 74° Innenkonus

Anschluss 2 UN/UNF-Außengewinde

Dichtform 2 74° Außenkonus

Bauart Aufschraub-Stutzen

Bauform Winkel 90°

Werkstoff Edelstahl

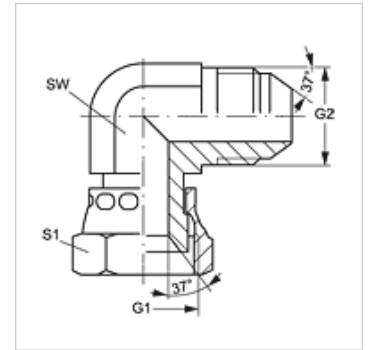

Artikel

Bezeichnung	G1	G2	SW (mm)	S1
W90 AJ 04 HJ VA	7/16" -20 UNF	7/16" -20 UNF	11	16
W90 AJ 05 HJ VA	1/2" -20 UNF	1/2" -20 UNF	13	17
W90 AJ 06 HJ VA	9/16" -18 UNF	9/16" -18 UNF	14	19
W90 AJ 08 HJ VA	3/4" -16 UNF	3/4" -16 UNF	19	22
W90 AJ 10 HJ VA	7/8" -14 UNF	7/8" -14 UNF	22	27
W90 AJ 12 HJ VA	1.1/16" -12 UN	1.1/16" -12 UN	27	32
W90 AJ 16 HJ VA	1.5/16" -12 UN	1.5/16" -12 UN	33	38
W90 AJ 20 HJ VA	1.5/8" -12 UN	1.5/8" -12 UN	41	50
W90 AJ 24 HJ VA	1.7/8" -12 UN	1.7/8" -12 UN	48	55

SW, S1, S2 = Schlüsselweite

Produktvarianten

W90 AJ HJ Aufschraub-Stutzen, Winkel 90°, Stahl