

FEDERRING

Federring

Eigenschaften

Bauart	Federring
Norm	DIN 127 Form B
Werkstoff	Federstahl

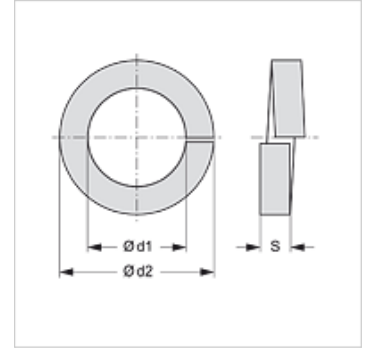

Artikel

Bezeichnung	Ø d1 (mm)	Ø d2 (mm)	S (mm)
FEDERRING M8	8,1	14,8	2,0
FEDERRING M10	10,2	18,1	2,2
FEDERRING M12	12,2	21,1	2,5
FEDERRING M14	14,2	24,1	3,0
FEDERRING M16	16,2	27,4	3,5
FEDERRING M20	20,2	33,6	4,0