

GFS G M (3000 / 6000 PSI)

SAE-Einschraubgegenflansch, BSP

HANSA FLEX

Eigenschaften

Norm	SAE J 518 C ISO 6162
Bauform	gerade
Bauart	SAE-Einschraubgegenflansch
Befestigung	Innengewinde für metr. Schrauben
Lieferumfang	nur Flansch
Werkstoff	S355J2G3
Oberfläche	schwarz geölt

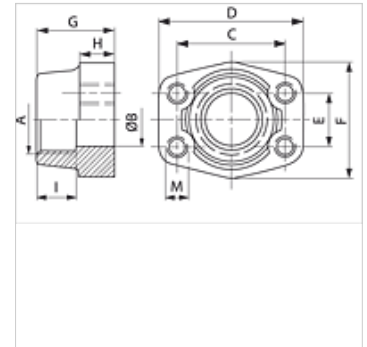

Hinweis

Der angeführte maximale Betriebsdruck ist bezogen auf den Flansch! Der tatsächliche Betriebsdruck wird bestimmt durch das Rohr (Wandstärke) sowie die Güte des Rohres!

Artikel

Bezeichnung	Druckreihe	PB 10.9 (bar)	Baugröße	A	Ø B (mm)	C (mm)	D (mm)	E (mm)	F (mm)	G (mm)	H (mm)	I (mm)	M metr.
GFS 80 G	3000 PSI	350	1/2"	G 1/2" -14	13	38,1	54	17,5	46	36	16	19	M8
GFS 80 G 3/8	3000 PSI	350	1/2"	G 3/8" -19	13	38,1	54	17,5	46	36	16	19	M8
GFS 100 G	3000 PSI	350	3/4"	G 3/4" -14	19	47,6	65	22,2	50	36	18	19	M10
GFS 100 G 1/2	3000 PSI	350	3/4"	G 1/2" -14	13	47,6	65	22,2	50	36	18	19	M10
GFS 102 G	3000 PSI	315	1"	G 1" -11	25	52,4	70	26,2	55	38	18	22	M10
GFS 102 G 3/4	3000 PSI	315	1"	G 3/4" -14	19	52,4	70	26,2	55	35	21	19	M10
GFS 104 G	3000 PSI	250	1.1/4"	G 1.1/4" -11	32	58,7	79	30,2	68	41	21	22	M10
GFS 104 G 1	3000 PSI	250	1.1/4"	G 1" -11	25	58,7	81	30,2	65	42	25	22	M10
GFS 106 G	3000 PSI	200	1.1/2"	G 1.1/2" -11	38	69,9	93	35,7	78	45	25	24	M12
GFS 106 G 1 1/4	3000 PSI	200	1.1/2"	G 1.1/4" -11	32	69,9	95	35,7	78	45	27	24	M12
GFS 108 G	3000 PSI	200	2"	G 2" -11	51	77,8	102	42,9	90	45	25	30	M12
GFS 108 G 1 1/2	3000 PSI	200	2"	G 1.1/2" -11	38	77,8	102	42,9	90	45	25	26	M12
GFS 110 G	3000 PSI	160	2.1/2"	G 2.1/2" -11	63	88,9	114	50,8	105	50	25	30	M12
GFS 110 G 2	3000 PSI	160	2.1/2"	G 2" -11	51	88,9	114	50,8	105	50	25	30	M12
GFS 112 G	3000 PSI	138	3"	G 3" -11	73	106,4	134	61,9	124	50	27	34	M16
GFS 112 G 2 1/2	3000 PSI	138	3"	G 2.1/2" -11	63	106,4	134	61,9	124	50	27	30	M16
GFS 114 G	3000 PSI	35	3.1/2"	G 3.1/2" -11	89	120,7	152	69,9	136	48	27	34	M16
GFS 114 G 3	3000 PSI	35	3.1/2"	G 3" -11	73	120,7	152	69,9	136	48	27	34	M16
GFS 116 G	3000 PSI	35	4"	G 4" -11	99	130,2	162	77,8	146	48	27	34	M16
GFS 116 G 3 1/2	3000 PSI	35	4"	G 3.1/2" -11	89	130,2	162	77,8	146	48	27	34	M16
GFS 401 G	6000 PSI	400	1/2"	G 1/2" -14	13	40,5	54	18,2	46	36	16	19	M8
GFS 401 G 3/8	6000 PSI	400	1/2"	G 3/8" -19	13	40,5	54	18,2	46	36	16	19	M8
GFS 402 G	6000 PSI	400	3/4"	G 3/4" -14	19	50,8	71	23,8	55	35	21	22	M10
GFS 402 G 1/2	6000 PSI	400	3/4"	G 1/2" -14	13	50,8	71	23,8	55	35	21	22	M10
GFS 403 G	6000 PSI	400	1"	G 1" -11	25	57,2	81	27,8	65	42	25	24	M12
GFS 403 G 3/4	6000 PSI	400	1"	G 3/4" -14	19	57,2	81	27,8	65	42	25	24	M12
GFS 404 G	6000 PSI	400	1.1/4"	G 1.1/4" -11	32	66,7	95	31,8	78	45	27	25	M14
GFS 404 G 1	6000 PSI	400	1.1/4"	G 1" -11	25	66,7	95	31,8	78	45	27	25	M14
GFS 405 G	6000 PSI	400	1.1/2"	G 1.1/2" -11	38	79,4	112	36,5	94	50	30	28	M16
GFS 405 G 1 1/4	6000 PSI	400	1.1/2"	G 1.1/4" -11	32	79,4	112	36,5	94	50	30	28	M16
GFS 406 G	6000 PSI	400	2"	G 2" -11	51	96,8	134	44,5	114	65	37	30	M20
GFS 406 G 1 1/2	6000 PSI	400	2"	G 1.1/2" -11	38	96,8	134	44,5	114	65	37	30	M20

PN = Nenndruck PB = max. Betriebsdruck

Produktvarianten

GFS G U (3000 / 6000 PSI) SAE-Einschraubgegenflansch, BSP, nur Flansch