

## Eigenschaften

<b>Anschluss 1</b>	UN/UNF-Außengewinde
<b>Dichtform 1</b>	74° Außenkonus
<b>Anschluss 2</b>	ORFS-Außengewinde
<b>Dichtform 2</b>	flachdichtend mit O-Ring
<b>Bauart</b>	Verbindungs-Stutzen
<b>Bauform</b>	gerade
<b>Werkstoff</b>	Stahl
<b>Oberfläche</b>	galvanisch beschichtet

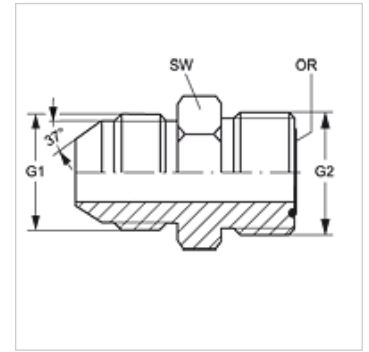

## Artikel

Bezeichnung	G1	G2	SW (mm)	OR
<b>G HJ 04 HJOF</b>	7/16" -20 UNF	9/16" -18 UNF	16	7,65 x 1,78
<b>G HJ 05 HJOF 06</b>	1/2" -20 UNF	11/16" -16 UN	19	9,25 x 1,78
<b>G HJ 06 HJOF</b>	9/16" -18 UNF	11/16" -16 UN	19	9,25 x 1,78
<b>G HJ 08 HJOF</b>	3/4" -16 UNF	13/16" -16 UN	22	12,42 x 1,78
<b>G HJ 10 HJOF</b>	7/8" -14 UNF	1" -14 UNS	27	15,60 x 1,78
<b>G HJ 12 HJOF</b>	1.1/16" -12 UN	1.3/16" -12 UN	32	18,77 x 1,78
<b>G HJ 16 HJOF</b>	1.5/16" -12 UN	1.7/16" -12 UN	38	23,53 x 1,78
<b>G HJ 20 HJOF</b>	1.5/8" -12 UN	1.11/16" -12 UN	45	29,87 x 1,78
<b>G HJ 24 HJOF</b>	1.7/8" -12 UN	2" -12 UN	54	37,82 x 1,78

SW = Schlüsselweite