

Eigenschaften

Anschluss 1	metrisches Außengewinde zylindrisch
Dichtform 1	O-Ring-Abdichtung am Einschraub-Stutzen
Anschluss 2	UN/UNF-Muttergewinde
Dichtform 2	74° Innenkonus
Bauart	Einschraub-Stutzen
Bauform	gerade
Werkstoff	Stahl
Oberfläche	galvanisch beschichtet

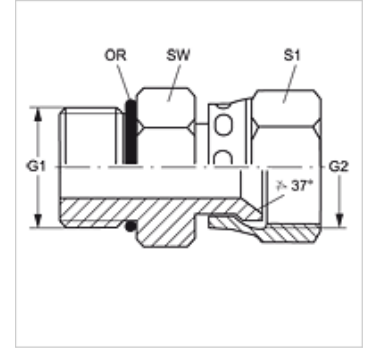

Artikel

Bezeichnung	G1	G2	SW (mm)	S1	OR
GE HMO 10 AJ 04	M 10 x 1	7/16" -20 UNF	14	16	8,2 x 1,5
GE HMO 10 AJ 05	M 10 x 1	1/2" -20 UNF	14	17	8,2 x 1,5
GE HMO 12 AJ 04	M 12 x 1,5	7/16" -20 UNF	17	16	9,4 x 2,1
GE HMO 12 AJ 05	M 12 x 1,5	1/2" -20 UNF	17	17	9,4 x 2,1
GE HMO 14 AJ 05	M 14 x 1,5	1/2" -20 UNF	19	17	11,4 x 2,1
GE HMO 14 AJ 06	M 14 x 1,5	9/16" -18 UNF	19	19	11,4 x 2,1
GE HMO 16 AJ 06	M 16 x 1,5	9/16" -18 UNF	22	19	13,4 x 2,1
GE HMO 16 AJ 08	M 16 x 1,5	3/4" -16 UNF	22	22	13,4 x 2,1
GE HMO 18 AJ 08	M 18 x 1,5	3/4" -16 UNF	24	22	15,4 x 2,1
GE HMO 18 AJ 10	M 18 x 1,5	7/8" -14 UNF	24	27	15,4 x 2,1
GE HMO 22 AJ 10	M 22 x 1,5	7/8" -14 UNF	27	27	19,4 x 2,1
GE HMO 22 AJ 12	M 22 x 1,5	1.1/16" -12 UN	27	32	19,4 x 2,1
GE HMO 27 AJ 12	M 27 x 2	1.1/16" -12 UN	32	32	23,7 x 2,8
GE HMO 27 AJ 16	M 27 x 2	1.5/16" -12 UN	32	38	23,7 x 2,8
GE HMO 33 AJ 16	M 33 x 2	1.5/16" -12 UN	41	38	29,7 x 2,8
GE HMO 42 AJ 20	M 42 x 2	1.5/8" -12 UN	50	50	38,7 x 2,8
GE HMO 48 AJ 24	M 48 x 2	1.7/8" -12 UN	60	60	46,7 x 2,8

SW, S1, S2 = Schlüsselweite