

GE HMO L HJ

Einschraub-Stutzen, lang

Eigenschaften

Anschluss 1	metrisches Außengewinde zylindrisch
Dichtform 1	O-Ring-Abdichtung am Einschraub-Stutzen
Anschluss 2	UN/UNF-Außengewinde
Dichtform 2	74° Außenkonus
Bauart	Einschraub-Stutzen lang
Bauform	gerade
Werkstoff	Stahl
Oberfläche	galvanisch beschichtet

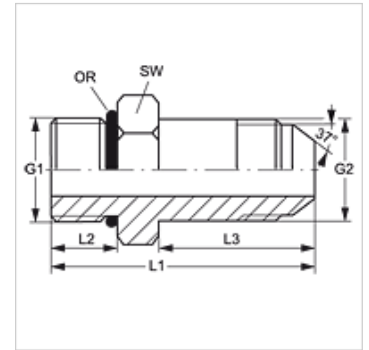

Artikel

Bezeichnung	G1	G2	L1 (mm)	L2 (mm)	L3 (mm)	SW (mm)	OR
GE HMO L 10 HJ 04	M 10 x 1	7/16" -20 UNF	51,0	9,0	35	15	8,00 x 1,50
GE HMO L 10 HJ 05	M 10 x 1	1/2" -20 UNF	53,0	9,0	37	15	8,00 x 1,50
GE HMO L 12 HJ 05	M 12 x 1,5	1/2" -20 UNF	55,5	11,0	37	18	9,30 x 2,40
GE HMO L 14 HJ 05	M 14 x 1,5	1/2" -20 UNF	56,5	11,0	37	20	11,30 x 2,40
GE HMO L 14 HJ 06	M 14 x 1,5	9/16" -18 UNF	58,5	11,0	39	20	11,30 x 2,40
GE HMO L 16 HJ 06	M 16 x 1,5	9/16" -18 UNF	60,0	12,5	39	23	13,30 x 2,40
GE HMO L 16 HJ 08	M 16 x 1,5	3/4" -16 UNF	69,0	12,5	48	23	13,30 x 2,40
GE HMO L 18 HJ 08	M 18 x 1,5	3/4" -16 UNF	70,5	13,5	48	25	15,30 x 2,40
GE HMO L 18 HJ 10	M 18 x 1,5	7/8" -14 UNF	75,5	13,5	53	25	15,30 x 2,40
GE HMO L 22 HJ 10	M 22 x 1,5	7/8" -14 UNF	78,0	15,0	53	28	19,30 x 2,40
GE HMO L 22 HJ 12	M 22 x 1,5	1.1/16" -12 UN	89,0	15,0	63	28	19,30 x 2,40
GE HMO L 27 HJ 12	M 27 x 2	1.1/16" -12 UN	92,5	18,5	63	32	23,47 x 2,95
GE HMO L 27 HJ 16	M 27 x 2	1.5/16" -12 UN	102,0	18,5	72	32	23,47 x 2,95
GE HMO L 33 HJ 16	M 33 x 2	1.5/16" -12 UN	102,5	18,5	72	42	29,74 x 2,95
GE HMO L 42 HJ 20	M 42 x 2	1.5/8" -12 UN	121,0	19,0	88	50	38,00 x 3,00
GE HMO L 48 HJ 24	M 48 x 2	1.7/8" -12 UN	136,0	22,0	98	56	44,04 x 3,00

SW = Schlüsselweite