

### Eigenschaften

<b>Anschluss 1</b>	BSPT-Außengewinde kegelig
<b>Dichtform 1</b>	gewindedichtend
<b>Anschluss 2</b>	BSP-Muttergewinde
<b>Dichtform 2</b>	60° Innenkonus
<b>Bauart</b>	Einschraub-Stutzen
<b>Bauform</b>	gerade
<b>Werkstoff</b>	Stahl
<b>Oberfläche</b>	galvanisch beschichtet

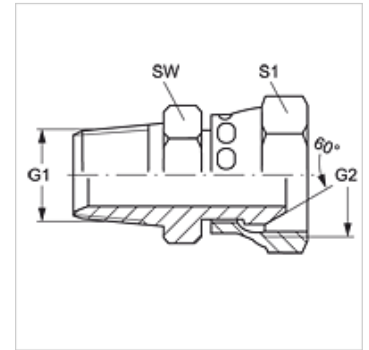

### Artikel

Bezeichnung	G1	G2	SW (mm)	S1
GE HRK 02 AB	R 1/8" K	G 1/8" -28	14	14
GE HRK 04 AB	R 1/4" K	G 1/4" -19	19	19
GE HRK 06 AB	R 3/8" K	G 3/8" -19	22	22
GE HRK 06 AB 08	R 3/8" K	G 1/2" -14	22	27
GE HRK 08 AB 06	R 1/2" K	G 3/8" -19	27	22
GE HRK 08 AB	R 1/2" K	G 1/2" -14	27	27
GE HRK 10 AB	R 5/8" K	G 5/8" -14	30	30
GE HRK 12 AB 08	R 3/4" K	G 1/2" -14	37	27
GE HRK 12 AB	R 3/4" K	G 3/4" -14	37	37
GE HRK 16 AB 12	R 1" K	G 3/4" -14	41	37
GE HRK 16 AB	R 1" K	G 1" -11	41	41
GE HRK 20 AB	R 1.1/4" K	G 1.1/4" -11	50	50
GE HRK 24 AB	R 1.1/2" K	G 1.1/2" -11	55	60
GE HRK 32 AB	R 2" K	G 2" -11	64	67

SW, S1, S2 = Schlüsselweite

### Produktvarianten

<b>GE HRK AB VA</b>	Einschraub-Stutzen, Edelstahl
---------------------	-------------------------------