

Eigenschaften

Anschluss 1	BSPT-Außengewinde kegelig
Dichtform 1	gewindedichtend
Anschluss 2	UN/UNF-Muttergewinde
Dichtform 2	74° Innenkonus
Bauart	Einschraub-Stutzen
Bauform	gerade
Werkstoff	Stahl
Oberfläche	galvanisch beschichtet

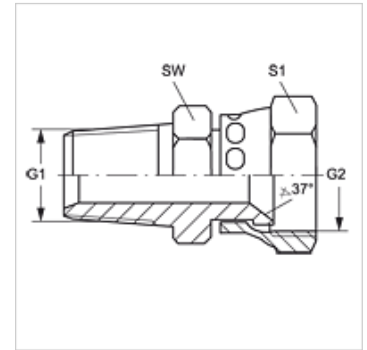

Artikel

Bezeichnung	G1	G2	SW (mm)	S1
GE HRK 02 AJ 04	R 1/8" K	7/16" -20 UNF	13	16
GE HRK 02 AJ 05	R 1/8" K	1/2" -20 UNF	13	17
GE HRK 04 AJ	R 1/4" K	7/16" -20 UNF	14	16
GE HRK 04 AJ 05	R 1/4" K	1/2" -20 UNF	14	17
GE HRK 04 AJ 06	R 1/4" K	9/16" -18 UNF	14	19
GE HRK 04 AJ 08	R 1/4" K	3/4" -16 UNF	19	22
GE HRK 06 AJ 05	R 3/8" K	1/2" -20 UNF	19	17
GE HRK 06 AJ	R 3/8" K	9/16" -18 UNF	19	19
GE HRK 06 AJ 08	R 3/8" K	3/4" -16 UNF	19	22
GE HRK 06 AJ 10	R 3/8" K	7/8" -14 UNF	22	27
GE HRK 08 AJ	R 1/2" K	3/4" -16 UNF	27	32
GE HRK 08 AJ 10	R 1/2" K	7/8" -14 UNF	22	27
GE HRK 08 AJ 12	R 1/2" K	1.1/16" -12 UN	27	32
GE HRK 12 AJ 10	R 3/4" K	7/8" -14 UNF	27	27
GE HRK 12 AJ	R 3/4" K	1.1/16" -12 UN	27	32
GE HRK 12 AJ 14	R 3/4" K	1.3/16" -12 UN	27	32
GE HRK 12 AJ 16	R 3/4" K	1.5/16" -12 UN	32	38
GE HRK 16 AJ	R 1" K	1.5/16" -12 UN	36	38
GE HRK 16 AJ 12	R 1" K	1.1/16" -12 UN	36	38
GE HRK 20 AJ	R 1.1/4" K	1.5/8" -12 UN	46	50
GE HRK 24 AJ	R 1.1/2" K	1.7/8" -12 UN	54	55

SW, S1, S2 = Schlüsselweite