

PA 500 AOS 45 A

Pressarmatur, DKOS W45°

HANSA FLEX

Eigenschaften

Einsatzbereich Pressarmatur für HD 500 Schläuche

Anschluss 1 metrisches Muttergewinde

Dichtform 1 24° Außenkonus mit O-Ring

Kürzel DKOS

Norm ISO 8434-1

Einbindung mit Ausreißsicherung (Interlock)

Lieferumfang Pressnippel + Pressfassung

Werkstoff Stahl

Oberfläche galvanisch beschichtet

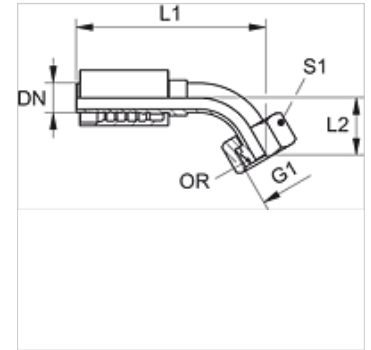

Artikel

Bezeichnung	DN	Size	Zoll	G1	für Rohr-Außen-Ø (mm)	L1 (mm)	L2 (mm)	S1	OR
PA 720 AOS 16 45	19	12	3/4"	M 30 x 2	20	133,0	27,0	36	16,0 x 2,5
PA 720 AOS 45	19	12	3/4"	M 36 x 2	25	136,0	30,0	46	20,0 x 2,5
PA 720 AOS 25 45	19	12	3/4"	M 42 x 2	30	142,0	35,0	50	27,0 x 2,5
PA 725 AOS 20 45	25	16	1"	M 36 x 2	25	156,5	34,5	41	22,0 x 2,5
PA 725 AOS 45	25	16	1"	M 42 x 2	30	164,0	34,5	50	25,0 x 2,5
PA 725 AOS 32 45	25	16	1"	M 52 x 2	38	170,0	41,0	60	33,0 x 2,5
PA 532 AOS 25 45 A	31	20	1"	M 42 x 2	30	175,0	39,5	50	27,0 x 2,5
PA 532 AOS 45 A	31	20	1.1/4"	M 52 x 2	38	192,5	41,0	60	33,0 x 2,5

Produktvarianten

PA 500 AOS 45 VA Pressarmatur, DKOS W45°, Edelstahl