

Eigenschaften

Anschluss 1	NPT-Muttergewinde (NPSM)
Dichtform 1	60° Außenkonus
Kürzel	DKN
Norm	ANSI B 1.20.0
Lieferumfang	Pressnippel + Pressfassung
Werkstoff	Stahl
Oberfläche	galvanisch beschichtet

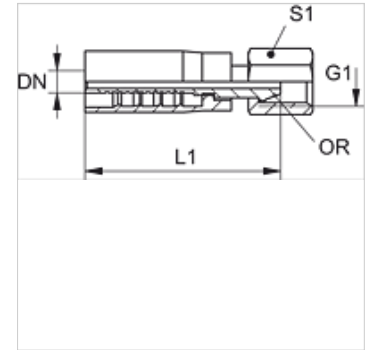

Artikel

Bezeichnung	DN	Size	Zoll	G1	L1 (mm)	S1
PAY 306 AN	6	4	1/4"	1/4" -18 NPT	47,0	19
PAY 308 AN 10	8	5	5/16"	3/8" -18 NPT	48,0	22
PAY 310 AN	10	6	3/8"	3/8" -18 NPT	50,0	22
PAY 313 AN	12	8	1/2"	1/2" -14 NPT	50,0	27
PAY 316 AN 20	16	10	5/8"	3/4" -14 NPT	53,0	32
PAY 320 AN	19	12	3/4"	3/4" -14 NPT	59,0	32
PAY 325 AN	25	16	1"	1" -11,5 NPT	-	-