

Eigenschaften

Anschluss 1	UN/UNF-Außengewinde
Dichtform 1	74° Außenkonus
Kürzel	AGJ
Norm	ISO 8434-2
Lieferumfang	Pressnippel + Pressfassung
Werkstoff	Stahl
Oberfläche	galvanisch beschichtet

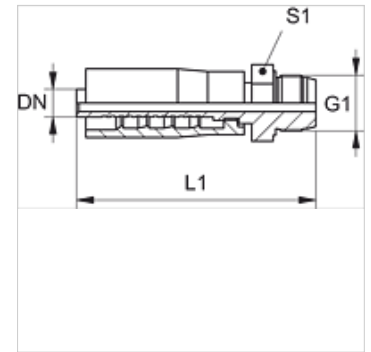

Artikel

Bezeichnung	DN	Size	Zoll	G1	L1 (mm)	S1
PAY 308 HJ 10	8	5	5/16"	9/16" -18 UNF	64,0	17
PAY 308 HJ 13	8	5	5/16"	3/4" -16 UNF	-	-
PAY 316 HJ 20	16	10	5/8"	1.1/16" -12 UN	94,0	30
PAY 320 HJ 25	19	12	3/4"	1.5/16" -12 UN	95,0	36
PAY 325 HJ 32	25	16	1"	1.5/8" -12 UN	97,0	46
PAY 332 HJ 40	31	20	1.1/4"	1.7/8" -12 UN	110,0	50