

Eigenschaften

Anschluss 1	NPT-Außengewinde
Dichtform 1	Gewindedichtend, zusätzlicher 60° Innenkonus.
Kürzel	AGN
Lieferumfang	Pressnippel + Pressfassung
Werkstoff	Stahl
Oberfläche	galvanisch beschichtet

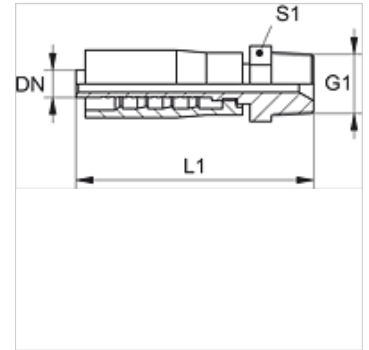

Artikel

Bezeichnung	DN	Size	Zoll	G1	L1 (mm)	S1
PAY 306 HN	6	4	1/4"	1/4" -18 NPT	65,0	14
PAY 306 HN 10	6	4	1/4"	3/8" -18 NPT	-	-
PAY 310 HN	10	6	3/8"	3/8" -18 NPT	71,0	19
PAY 310 HN 13	10	6	3/8"	1/2" -14 NPT	76,0	22
PAY 313 HN	12	8	1/2"	1/2" -14 NPT	79,0	22
PAY 320 HN	19	12	3/4"	3/4" -14 NPT	91,0	27
PAY 325 HN	25	16	1"	1" -11,5 NPT	96,0	36
PAY 325 HN 32	25	16	1"	1.1/4" -11,5 NPT	97,0	46