

Eigenschaften

Einsatzbereich	Pressnippel für HD 100- bis HD 400-, KP-, TE-Schläuche
geeignet für	Toyota
Anschluss 1	BSP-Muttergewinde
Dichtform 1	60° Innenkonus
Norm	JIS 8363
Werkstoff	Stahl
Oberfläche	galvanisch beschichtet

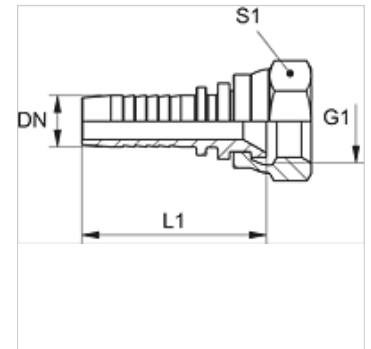

Hinweis

Die passende Fassung bitte nach dem Schlauchtyp auswählen.

Artikel

Bezeichnung	DN	Size	Zoll	Betriebsdruck (bar)	G1	L1 (mm)	S1
PN 06 ARI 02	6	4	1/4"	-	G 1/8" -28	41,5	14
PN 06 ARI	6	4	1/4"	-	G 1/4" -19	42,5	19
PN 08 ARI 06	8	5	5/16"	-	G 1/4" -19	42,5	19
PN 08 ARI 10	8	5	5/16"	-	G 3/8" -19	43,0	22
PN 10 ARI	10	6	3/8"	-	G 3/8" -19	45,5	22
PN 13 ARI	12	8	1/2"	345,0	G 1/2" -14	48,0	27
PN 20 ARI	19	12	3/4"	275,0	G 3/4" -14	60,0	32
PN 25 ARI	25	16	1"	205,0	G 1" -11	71,0	38
PN 32 ARI	31	20	1.1/4"	170,0	G 1.1/4" -11	84,0	50
PN 40 ARI	38	24	1.1/2"	105,0	G 1.1/2" -11	88,5	55