

T AJ HJ VA

Aufschraub-Stutzen, T-Form

HANSA FLEX

Eigenschaften

Anschluss 1	UN/UNF-Muttergewinde
Dichtform 1	74° Innenkonus
Anschluss 2 + 3	UN/UNF-Außengewinde
Dichtform 2 + 3	74° Außenkonus
Bauart	Aufschraub-Stutzen richtungseinstellbar
Bauform	T-Form
Werkstoff	Edelstahl

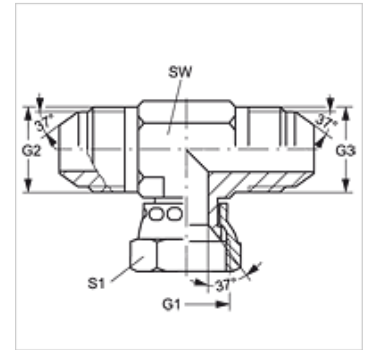

Artikel

Bezeichnung	G1	G2 + G3	SW (mm)	S1
T AJ 04 HJ VA	7/16" -20 UNF	7/16" -20 UNF	11	16
T AJ 05 HJ VA	1/2" -20 UNF	1/2" -20 UNF	13	17
T AJ 06 HJ VA	9/16" -18 UNF	9/16" -18 UNF	14	19
T AJ 08 HJ VA	3/4" -16 UNF	3/4" -16 UNF	19	22
T AJ 10 HJ VA	7/8" -14 UNF	7/8" -14 UNF	22	27
T AJ 12 HJ VA	1.1/16" -12 UN	1.1/16" -12 UN	27	32
T AJ 16 HJ VA	1.5/16" -12 UN	1.5/16" -12 UN	33	38
T AJ 20 HJ VA	1.5/8" -12 UN	1.5/8" -12 UN	41	50
T AJ 24 HJ VA	1.7/8" -12 UN	1.7/8" -12 UN	48	55

SW, S1, S2 = Schlüsselweite

Produktvarianten

T AJ HJ Aufschraub-Stutzen, T-Form, Stahl