

# T IN HJ

Aufschraub-Stutzen, T-Form

**HANSA FLEX**

## Eigenschaften

<b>Anschluss 1</b>	NPT-Innengewinde
<b>Dichtform 1</b>	gewindedichtend
<b>Anschluss 2 + 3</b>	UN/UNF-Außengewinde
<b>Dichtform 2 + 3</b>	74° Außenkonus
<b>Bauart</b>	Aufschraub-Stutzen
<b>Bauform</b>	T-Form
<b>Werkstoff</b>	Stahl
<b>Oberfläche</b>	galvanisch beschichtet

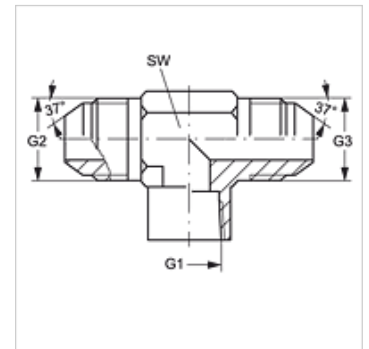

## Artikel

Bezeichnung	G1	G2 + G3	SW (mm)
T IN 02 HJ 04	1/8" -27 NPT	7/16" -20 UNF	14
T IN 02 HJ 05	1/8" -27 NPT	1/2" -20 UNF	14
T IN 04 HJ	1/4" -18 NPT	7/16" -20 UNF	19
T IN 04 HJ 05	1/4" -18 NPT	1/2" -20 UNF	19
T IN 04 HJ 06	1/4" -18 NPT	9/16" -18 UNF	19
T IN 04 HJ 08	1/4" -18 NPT	3/4" -16 UNF	19
T IN 06 HJ	3/8" -18 NPT	9/16" -18 UNF	22
T IN 06 HJ 08	3/8" -18 NPT	3/4" -16 UNF	22
T IN 08 HJ 10	1/2" -14 NPT	7/8" -14 UNF	27
T IN 08 HJ 12	1/2" -14 NPT	1.1/16" -12 UN	27
T IN 12 HJ	3/4" -14 NPT	1.1/16" -12 UN	33
T IN 16 HJ	1" -11,5 NPT	1.5/16" -12 UN	41
T IN 20 HJ	1.1/4" -11,5 NPT	1.5/8" -12 UN	48
T IN 24 HJ	1.1/2" -11,5 NPT	1.7/8" -12 UN	64

SW = Schlüsselweite

## Produktvarianten

T IN HJ VA Aufschraub-Stutzen, T-Form, Edelstahl