

TR G VB

Verbinder für Tecalan-Rohr

HANSA FLEX

Eigenschaften

Bauform	gerade
Bauart	Steckverbinder
Werkstoff	Messing
Oberfläche	vernickelt

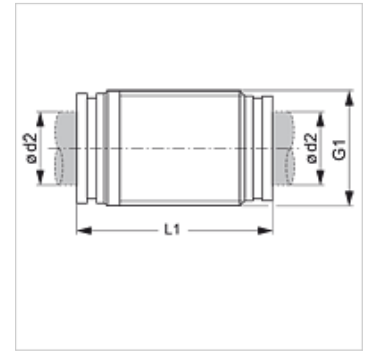

Artikel

Bezeichnung	Ø d2 (mm)	G1	L1 (mm)
TR 04 G VB	4	M 11 x 1	28,6
TR 05 G VB	5	M 14 x 1	33,5
TR 06 G VB	6	M 13 x 1	31,2
TR 08 G VB	8	M 15 x 1	33,9
TR 10 G VB	10	M 17 x 1	37,8
TR 12 G VB	12	M 20 x 1	39,7
TR 14 G VB	14	M 24 x 1	45,5