

Eigenschaften

Anschluss 1	Rohrstutzen
Dichtform 1	Schneidringanschluss
Kürzel	BES
Norm	ISO 8434-1
Lieferumfang	Pressnippel + Pressfassung
Werkstoff	Stahl
Oberfläche	galvanisch beschichtet

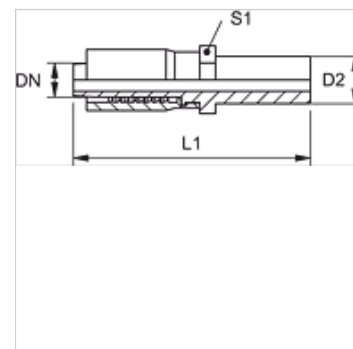

Hinweis

Die Schneidring-Endmontage muss im gehärteten Vormontagegestutzen (VOM...) erfolgen.

Artikel

Bezeichnung	DN	Size	Zoll	Baureihe	D2 (mm)	L1 (mm)	SW (mm)
TRP 04 FS	5	3	3/16"	S	8,0	59,0	14
TRP 06 FS	6	4	1/4"	S	10,0	67,0	14
TRP 06 FS 04	6	4	1/4"	S	8,0	65,0	14
TRP 06 FS 08	6	4	1/4"	S	12,0	68,0	17
TRP 08 FS	8	5	5/16"	S	12,0	71,0	17
TRP 08 FS 06	8	5	5/16"	S	10,0	70,0	17
TRP 10 FS	10	6	3/8"	S	14,0	79,0	19
TRP 10 FS 06	10	6	3/8"	S	10,0	75,0	19
TRP 10 FS 08	10	6	3/8"	S	12,0	77,0	19
TRP 13 FS	12	8	1/2"	S	16,0	87,0	24