

Eigenschaften

Werkstoff Stahl S355J0 (Fe510C)

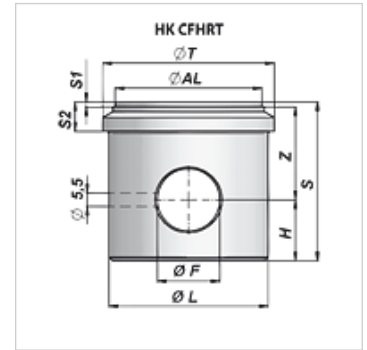

Artikel

Bezeichnung	Ø AL (mm)	Ø F (mm)	Ø T (mm)	H (mm)	Ø L (mm)	S (mm)	S1 (mm)	Z (mm)	S2 (mm)	Gewicht (kg)
HK CFHRT 040 30	30	14,00	40	14	-	30	2	14	-	0,23
HK CFHRT 060 50	50	23,00	60	22	-	50	2	26	-	0,90
HK CFHRT 070 60	60	25,50	70	25	65	65	2	38	12	1,48