

Eigenschaften

Einsatzbereich	Landmaschinen
Werkstoff	Stahl C40

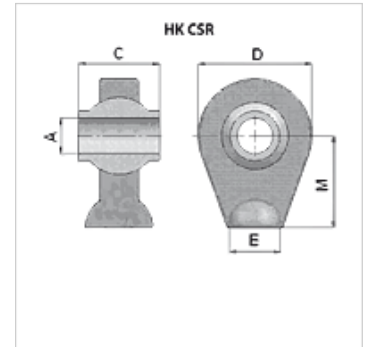

Artikel

Bezeichnung	C (mm)	E	M (mm)	A (mm)	Ausführung	D (mm)	Gewicht (kg)
HK CSR 00 107 08	44,0	Ø 34	58,00	19,3	planbearbeitet	62	0,60
HK CSR 00 107 20	44,0	Ø 34	58,00	20,2	planbearbeitet	62	0,60
HK CSR 00 107 25	35,0	Ø 26	50,00	22,2	rauh	62	0,55
HK CSR 00 107 40	51,0	Ø 38	65,00	25,4	planbearbeitet	75	1,10
HK CSR 00 108 10	55,0	Ø 50	65,00	30,2	planbearbeitet	83	1,40
HK CSR 00 108 12	35,0	Ø 50	65,00	35,2	planbearbeitet	83	1,20
HK CSR 00 108 20	75,0	Ø 60	85,00	40,2	planbearbeitet	108	3,35
HK CSR 00 108 40	75,0	Ø 60	85,00	45,2	planbearbeitet	108	3,15
HK CSR 00 108 60	75,0	Ø 60	85,00	50,2	planbearbeitet	108	2,90