

Eigenschaften

Werkstoff Stahl S355J0 (Fe510C)

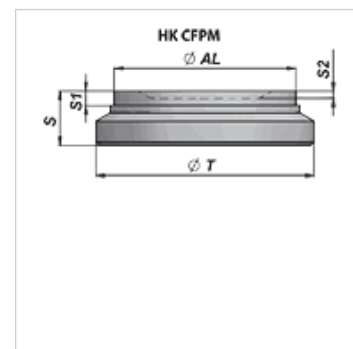
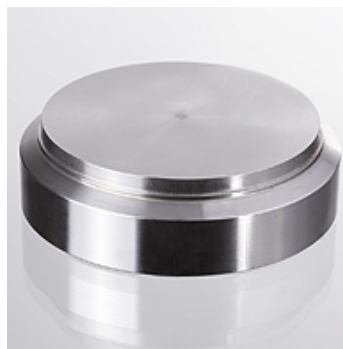

Artikel

Bezeichnung	Ø AL (mm)	Ø T (mm)	S (mm)	S1 (mm)	S2 (mm)	Gewicht (kg)
HK CFPM 060 050 017	50	60	17	4	2	0,30
HK CFPM 065 050 017	50	65	17	4	-	0,36
HK CFPM 070 060 021	60	70	21	4	-	0,50
HK CFPM 075 060 019	60	75	19	4	-	0,56
HK CFPM 080 070 024	70	80	24	4	-	0,80
HK CFPM 085 070 022	70	85	22	4	2	0,85
HK CFPM 095 080 027	80	95	27	4	-	1,10
HK CFPM 100 080 025	80	100	25	4	2	1,30
HK CFPM 110 090 026	90	110	26	4	-	1,70
HK CFPM 115 100 033	100	115	33	4	-	2,20
HK CFPM 120 100 030	100	120	30	4	2	2,30
HK CFPM 125 110 036	110	125	36	7	-	2,90
HK CFPM 135 110 033	110	135	33	7	-	3,50
HK CFPM 140 120 040	120	140	40	7	-	3,80
HK CFPM 145 120 035	120	145	35	7	-	4,20
HK CFPM 170 140 040	140	170	40	7	2	6,40