

Eigenschaften

Bauart	Abstreifer
Gleitgeschw. max.	0,5 m/s
Temp. min.	-30 °C
Temp. max.	80 °C
Medien	Mineralöle
Montage	Abstreifer nierenförmig verformen und in die Aufnahmenut drücken
Anwendung	Hydraulik
Werkstoff	PUR

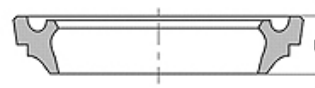

Toleranz / Tolerance						
d	D	L	C	F	G	
h11	H11	+0,20 0	H10	H11	+0,20 0	



Beschreibung

Streift auch Lecköl vom Dichtraum ab.
Einfache Montage.

Artikel

Bezeichnung	D (mm)	d (mm)	L (mm)	C (mm)	F (mm)	G (mm)	E (mm)	H (mm)
DSR 18-UP	26	18	4,0	24	21,5	6,0	2	8
DSR 22-UP	22	22	4,0	28	25,5	6,0	2	8
DSR 32-UP	40	32	4,0	38	35,5	6,0	2	8
DSR 35-UP	43	35	4,0	41	38,5	6,0	2	8
DSR 36-UP	44	36	4,0	42	39,5	6,0	2	8
DSR 40-UP	48	40	4,0	46	43,5	6,0	2	8
DSR 45-UP	53	45	4,0	51	48,5	6,0	2	8
DSR 50-UP	58	50	4,0	56	53,5	6,0	2	8
DSR 55-UP	63	55	4,0	61	58,5	6,0	2	8
DSR 56-UP	64	56	4,0	62	59,5	6,0	2	8
DSR 60-UP	68	60	4,0	66	63,5	6,0	2	8
DSR 63-UP	71	63	4,0	69	66,5	6,0	2	8
DSR 80-UP	88	80	4,0	86	83,5	6,0	2	8
DSR 90-UP	98	90	4,0	96	93,5	6,0	2	8
DSR 100-UP	108	100	4,0	106	103,5	6,0	2	8