

OR 70° Shore Silicon

O-Ring, 70SH Silikon

HANSA FLEX

Eigenschaften

Bauart O-Ring

Werkstoff Silikon 70 Shore

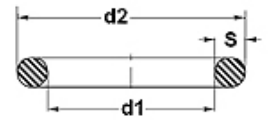

Bestellnummer / Item code	
OR 36.09-3.53 V	
d1 (mm) x 100	Werkstoff / Material s (mm) x 100

Artikel

Bezeichnung	d1 (mm)	d2 (mm)	s (mm)
OR 36.09-3.53 S70	36,09	43,15	3,53
OR 266.29-3.53 S70	266,29	273,35	3,53
OR 304.39-3.53 S70	304,39	311,45	3,53
OR 329.57-7 S70	329,57	343,57	7,00