

UWR-P

Doppelabstreifer, UWR-P

HANSA FLEX

Eigenschaften

Bauart	Doppelabstreifer
Gleitgeschw. max.	0,5 m/s
Temp. min.	-30 °C
Temp. max.	80 °C
Medien	Mineralöle
Montage	Abstreifer nierenförmig verformen und in die Aufnahme Nut drücken
Werkstoff	PUR
Anwendung	Hydraulik

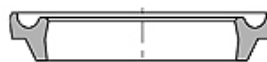

Toleranz / Tolerance			
d	D	L	C
h11	+0,20 0	+0,10 0	+0,20 0

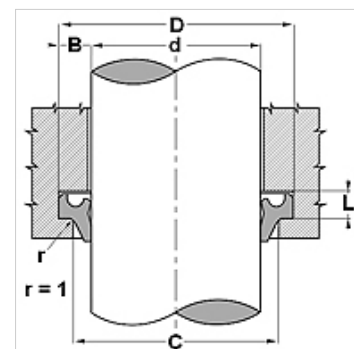

Beschreibung

Einfache Montage.

Streift auch Lecköl vom Dichtraum ab.

Artikel

Bezeichnung	d (mm)	D (mm)	L (mm)	C (mm)
UWR-P 12	12	18,6	3,8	15,0
UWR-P 18	18	24,6	3,8	21,0
UWR-P 20	20	28,6	5,3	23,0
UWR-P 22	22	30,6	5,3	25,0
UWR-P 24	24	32,6	5,3	27,0
UWR-P 25-1	25	25,0	4,0	27,5
UWR-P 25	25	33,6	5,3	28,0
UWR-P 28-1	28	28,0	5,0	31,0
UWR-P 28	28	36,6	5,3	31,0
UWR-P 30	30	38,6	5,3	33,0
UWR-P 32	32	40,6	5,3	35,0
UWR-P 35-1	35	35,0	5,0	38,0
UWR-P 35	35	43,6	5,3	38,0
UWR-P 36	36	44,6	5,3	39,0
UWR-P 40	40	48,6	5,3	43,0
UWR-P 45	45	53,6	5,3	48,0
UWR-P 50-1	50	50,0	5,0	53,0
UWR-P 50	50	58,6	5,3	53,0
UWR-P 55	55	63,6	5,3	58,0
UWR-P 56	56	64,6	5,3	59,0
UWR-P 60	60	68,6	5,3	63,0
UWR-P 63	63	71,6	5,3	66,0
UWR-P 65	65	73,6	5,3	68,0
UWR-P 70	70	78,6	5,3	73,0
UWR-P 75	75	83,6	5,3	78,0
UWR-P 80	80	88,6	5,3	83,0
UWR-P 85	85	97,2	7,1	91,0
UWR-P 90-1	90	90,0	6,0	93,0
UWR-P 90	90	102,2	7,1	96,0
UWR-P 100	100	112,2	7,1	106,0
UWR-P 110	110	122,2	7,1	116,6