

AC OR AOL

O-Ring für DKOL Klima

Eigenschaften

Temp. min.	-40 °C
Temp. max.	125 °C
Werkstoff	NBR

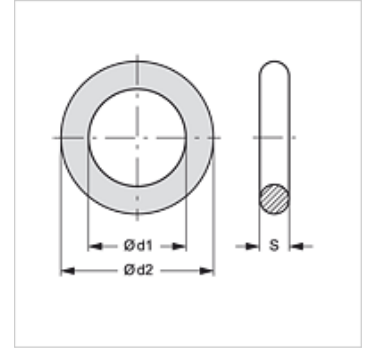

Artikel

Bezeichnung	für Schlauch DN	Ø d1 (mm)	Ø d2 (mm)	S (mm)
AC OR AOL 20	19	20	24	2,0
AC OR AOL 25	25	26	30	2,0
AC OR AOL 32	31	32	37	2,5