

K 403-58 - K 403-67

Dichtring für Stoßverbindung

HANSA FLEX

Eigenschaften

Norm DIN 74297 Zn

Werkstoff Zink

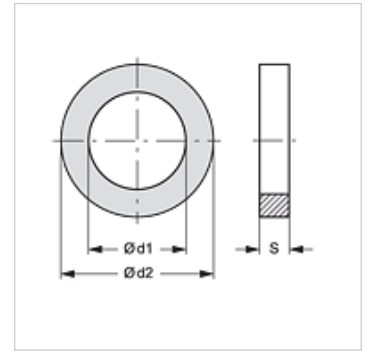

Artikel

Bezeichnung	$\varnothing d1$ (mm)	$\varnothing d2$ (mm)	S (mm)
K 403-59	14	20	1,50
K 403-66	12	19	1,50
K 403-67	15	24	1,50