

HK CSR 104

Gelenkkopf

HANSA FLEX

Eigenschaften

Einsatzbereich Landmaschinen

Werkstoff Stahl C40

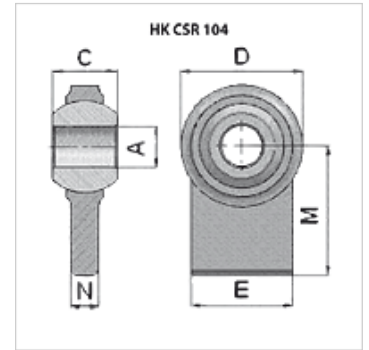

Artikel

Bezeichnung	C (mm)	E (mm)	M (mm)	N (mm)	A (mm)	D (mm)	Gewicht (kg)
HK CSR 00 104 95	20,0	30	60,00	11,0	16,2	46	0,26