

TUE FF PN16

FEST-Flansch, mit gezahnten Stutzen, PN10/16, Stahl VZ

HANSA FLEX

Eigenschaften

Anschluss 1	Festflansch in der Druckstufe PN16
Bauform	gerade
Dichtform 1	flachdichtend
Einsatzbereich	Industrie
Norm	DIN EN 1092-1

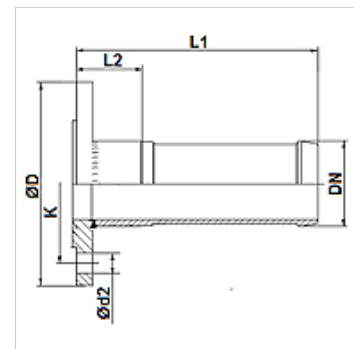

Artikel

Bezeichnung	DN*	Size	Zoll	Ø D (mm)	K (mm)	Ø d2 (mm)	N (mm)
TUE 20 FF PN16	20	12	3/4"	105,0	75	14	4
TUE 25 FF PN16	25	16	1"	115,0	85	14	4
TUE 32 FF PN16	32	20	1.1/4"	140,0	100	18	4
TUE 38 FF PN16	40	24	1.1/2"	150,0	110	18	4
TUE 50 FF PN16	50	32	2"	165,0	125	18	4
TUE 63 FF PN16	63	40	2.1/2"	185,0	145	18	4
TUE 75 FF PN16	75	50	3"	200,0	160	18	8
TUE 102 FF PN16	100	64	4"	220,0	180	18	8

N = Lochanzahl

Zubehör

KS AL	Klemmschale, Aluminium
KS FIX AL	Klemmschale zum verstemmen, Aluminium

Zusatzelemente

FD C4400	Flachdichtung
-----------------	---------------