

K-VT 2-FACH MS NI

Verteiler, 2fach, Messing vernickelt

Eigenschaften

Betriebsdruck max. 10 bar

Werkstoff Messing vernickelt

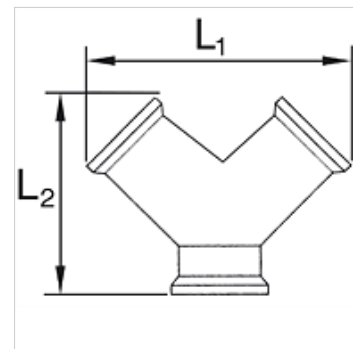

Hinweis

Weitere Angaben auf Anfrage.

Artikel

Bezeichnung	Gewinde	Abgänge	L1 (mm)	L2 (mm)
K- 07 40 40 14	G 1/8 außen	2 x innen	29,0	32,0
K- 07 40 40 15	G 1/4 außen	2 x innen	36,0	38,0
K- 07 40 45 63	G 3/8 außen	2 x innen	41,0	42,5
K- 07 40 45 62	G 1/2 außen	2 x innen	53,0	53,0
K- 07 40 45 66	G 1/8 innen	2 x innen	29,0	26,5
K- 07 40 40 82	G 1/4 innen	2 x innen	36,0	32,0
K- 07 40 40 85	G 3/8 innen	2 x innen	41,0	37,0
K- 07 40 40 86	G 1/2 innen	2 x innen	53,0	45,0