

K-DRV 1

Drosselrückschlagventile

Eigenschaften

Betriebsdruck max. 10 bar

Betriebstemperatur max. 70 °C

Dichtmaterial NBR

Gehäuse Aluminium

Innentteile Aluminium/Messing

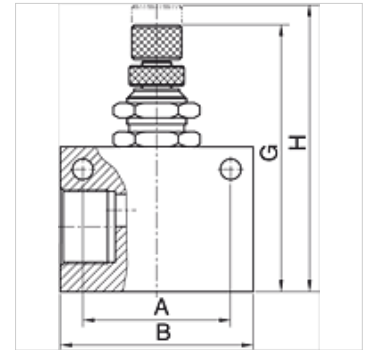

Hinweis

Weitere Angaben auf Anfrage.

Artikel

Bezeichnung	Gewinde	A (mm)	B (mm)	G (mm)	H (mm)
K- 07 30 12 32	G 1/8	22,0	32,0	46,90	52,3
K- 07 30 12 33	G 1/4	26,0	36,0	50,80	56,3
K- 07 30 12 34	G 3/8	35,0	50,0	65,00	74,0
K- 07 30 12 35	G 1/2	35,0	50,0	65,00	74,0