

K-KRONENBOHR SCHN-FLAN 20-63 INFI

Kronenbohrer für Schnellflansch Ø 20 mm – Ø 63 mm

HANSA FLEX

Eigenschaften

Werkstoff Stahl (HSS)

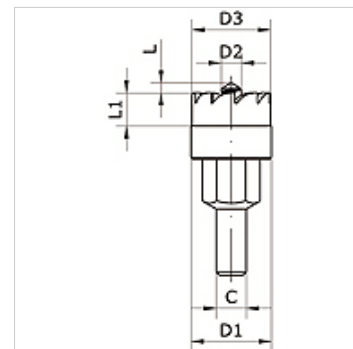
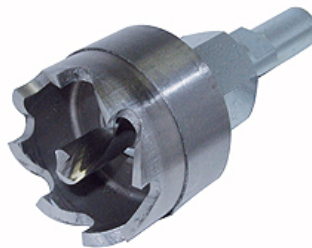

Artikel

Bezeichnung	für Rohr-Außen-Ø mm	C (mm)	D1 (mm)	D2 (mm)	D3 (mm)	L (mm)	L1 (mm)
K- 07 40 54 52	32, 40	9,0	24,0	6	23,5	3,0	10,0
K- 07 40 54 53	50, 63	9,0	31,0	6	30,5	3,0	9,0