

Eigenschaften

| | |
|---------------------|----------------------------|
| Anschluss 1 | BSP-Muttergewinde |
| Dichtform 1 | 60° Außenkonus |
| Kürzel | DKR |
| Norm | ISO 8434-6 BS 5200 |
| Lieferumfang | Pressnippel + Pressfassung |
| Werkstoff | Stahl |
| Oberfläche | galvanisch beschichtet |

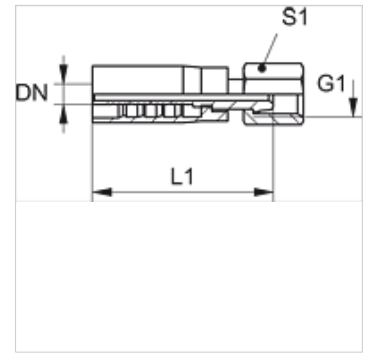

Artikel

| Bezeichnung | DN | Size | Zoll | G1 | L1 (mm) | S1 | SW (mm) |
|---------------|----|------|-------|--------------|------------|----|------------|
| PAY 506 AB | 6 | 4 | 1/4" | G 1/4" -19 | - | - | - |
| PAY 508 AB 10 | 8 | 5 | 5/16" | G 3/8" -19 | - | 27 | - |
| PAY 510 AB | 10 | 6 | 3/8" | G 3/8" -19 | - | 22 | - |
| PAY 513 AB | 12 | 8 | 1/2" | G 1/2" -14 | 79,0 | 27 | 14 |
| PAY 516 AB 20 | 16 | 10 | 5/8" | G 3/4" -14 | 86,3 | 32 | 19 |
| PAY 520 AB | 19 | 12 | 3/4" | G 3/4" -14 | - | 32 | - |
| PAY 520 AB 25 | 19 | 12 | 3/4" | G 1" -11 | 94,0 | 41 | 24 |
| PAY 525 AB | 25 | 16 | 1" | G 1" -11 | - | 41 | - |
| PAY 525 AB 32 | 25 | 16 | 1" | G 1.1/4" -11 | 104,0 | 50 | 30 |