

SRD VA

Cutting ring

Properties

Design	Cutting ring
Standard	DIN 3861 shape B
Material	Stainless steel

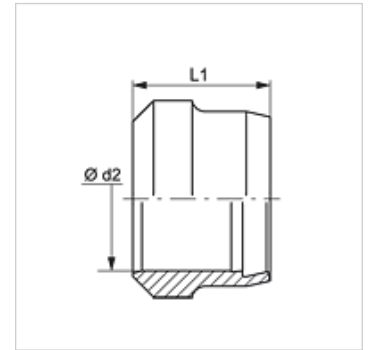

Note

Information about fitting, installation, pressure loads and permissible operating temperatures can be found in the technical information for pipe fittings.

Item

Identification	Series	Ø d2 (mm)	L1 (mm)
SRD 04 LL VA	LL	4	6,0
SRD 06 LL VA	LL	6	7,0
SRD 08 LL VA	LL	8	7,0
SRD 06 VA	L / S	6	9,5
SRD 08 VA	L / S	8	9,5
SRD 10 VA	L / S	10	10,0
SRD 12 VA	L / S	12	10,0
SRD 14 VA	S	14	10,0
SRD 15 VA	L	15	10,0
SRD 16 VA	S	16	10,5
SRD 18 VA	L	18	10,0
SRD 20 VA	S	20	12,5
SRD 22 VA	L	22	10,5
SRD 25 VA	S	25	12,5
SRD 28 VA	L	28	10,5
SRD 30 VA	S	30	13,0
SRD 35 VA	L	35	13,0
SRD 38 VA	S	38	13,5
SRD 42 VA	L	42	13,0

Series: LL = Very light L = Light S = Heavy – PN = Nominal pressure PB = Max. operating pressure – Ø d2 = External pipe diameter

Product versions

SRD	Cutting ring, Steel
SRD MG	Cutting ring, Brass