

Properties

Connection 1	metric cylindrical outer thread
Sealing form 1	Shape E
Connection 2	metric nut thread
Sealing form 2	Pipe socket with cutting ring
Design	Screw-in fitting
Construction	straight
Standard	DIN 2353 ISO 8434-1
Scope of supply	Pipe socket with union nut and pre-assembled cutting ring
Material	Steel
Surface	electro galvanised

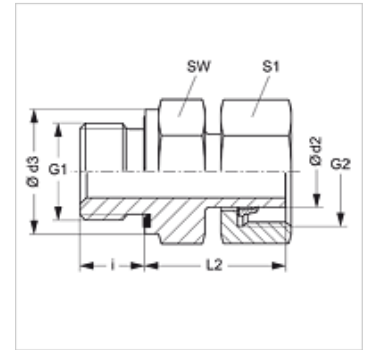

Note

Information about fitting, installation, pressure loads and permissible operating temperatures can be found in the technical information for pipe fittings.

Item

Identification	Series	Operating pressure	Ø d2 (mm)	G1	G2	Ø d3 (mm)	i (mm)	L2 (mm)	AF (mm)	S1
AVM NW 04 L ED	L	PN 315	6	M 10 x 1	M 12 x 1.5	13,9	8	24,5	14	14
AVM NW 06 L ED	L	PN 315	8	M 12 x 1.5	M 14 x 1.5	16,9	12	26,5	17	17
AVM NW 08 L ED	L	PN 315	10	M 14 x 1.5	M 16 x 1.5	18,9	12	27,5	19	19
AVM NW 10 L ED	L	PN 315	12	M 16 x 1.5	M 18 x 1.5	21,9	12	30,5	22	22
AVM NW 13 L ED	L	PN 315	15	M 18 x 1.5	M 22 x 1.5	23,9	12	31,5	24	27
AVM NW 16 L ED	L	PN 315	18	M 22 x 1.5	M 26 x 1.5	26,9	14	31,5	27	32
AVM NW 20 L ED	L	PN 160	22	M 26 x 1.5	M 30 x 2	31,9	16	32,5	32	36
AVM NW 25 L ED	L	PN 160	28	M 33 x 2	M 36 x 2	39,9	18	35,0	41	41
AVM NW 32 L ED	L	PN 160	35	M 42 x 2	M 45 x 2	49,9	20	42,5	50	50
AVM NW 40 L ED	L	PN 160	42	M 48 x 2	M 52 x 2	54,9	22	46,5	55	60
AVM NW 03 S ED	S	PN 630	6	M 12 x 1.5	M 14 x 1.5	16,9	12	27,0	17	17
AVM NW 04 S ED	S	PN 630	8	M 14 x 1.5	M 16 x 1.5	18,9	12	29,5	19	19
AVM NW 06 S ED	S	PN 630	10	M 16 x 1.5	M 18 x 1.5	21,9	12	32,0	22	22
AVM NW 08 S ED	S	PN 630	12	M 18 x 1.5	M 20 x 1.5	23,9	12	34,0	24	24
AVM NW 10 S ED	S	PN 630	14	M 20 x 1.5	M 22 x 1.5	25,9	14	36,5	27	27
AVM NW 13 S ED	S	PN 400	16	M 22 x 1.5	M 24 x 1.5	26,9	14	37,0	27	30
AVM NW 16 S ED	S	PN 400	20	M 27 x 2	M 30 x 2	31,9	16	43,0	32	36
AVM NW 20 S ED	S	PN 400	25	M 33 x 2	M 36 x 2	39,9	18	48,0	41	46
AVM NW 25 S ED	S	PN 400	30	M 42 x 2	M 42 x 2	49,9	20	51,0	50	50
AVM NW 32 S ED	S	PN 315	38	M 48 x 2	M 52 x 2	54,9	22	60,0	55	60

Series: LL = Very light L = Light S = Heavy - PN = Nominal pressure PB = Max. operating pressure - Ø d2 = External pipe diameter

Product versions

AVM ED VA Screw-in fitting, Stainless steel

Spare parts

WD Soft seal for ED fittings