

Properties

Connection 1	metric cylindrical outer thread
Sealing form 1	Shape B
Connection 2	Pipe socket not pre-assembled
Sealing form 2	Cutting ring connection
Design	Screw-in sockets
Construction	straight
Standard	DIN 2353 ISO 8434-1
Scope of supply	Socket (without union nut and cutting ring)
Material	Stainless steel

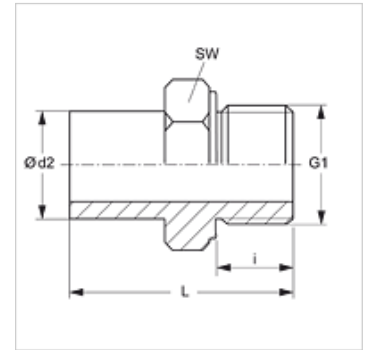

Note

Information about fitting, installation, pressure loads and permissible operating temperatures can be found in the technical information for pipe fittings.

Item

Identification	Series	Operating pressure	Ø d2 (mm)	G1	i (mm)	L (mm)	AF (mm)
NVM NW 03 S VA	S	PN 630	6	M 12 x 1.5	12	39,0	17
NVM NW 04 S VA	S	PN 630	8	M 14 x 1.5	12	41,5	19
NVM NW 06 S VA	S	PN 630	10	M 16 x 1.5	12	44,0	22
NVM NW 08 S VA	S	PN 630	12	M 18 x 1.5	12	46,0	24
NVM NW 10 S VA	S	PN 630	14	M 20 x 1.5	14	50,0	27
NVM NW 13 S VA	S	PN 400	16	M 22 x 1.5	14	51,0	27
NVM NW 16 S VA	S	PN 400	20	M 27 x 2	16	59,0	32
NVM NW 20 S VA	S	PN 400	25	M 33 x 2	18	66,0	46
NVM NW 25 S VA	S	PN 400	30	M 42 x 2	20	51,0	50
NVM NW 32 S VA	S	PN 315	38	M 48 x 2	22	82,0	55

Series: LL = Very light L = Light S = Heavy – PN = Nominal pressure PB = Max. operating pressure – Ø d2 = External pipe diameter

Product versions

NVM Screw-in sockets, Steel

Additional elements

VOM Pre-assembly sockets