

Properties

Connection 1	BSPT conical external threads
Sealing form 1	thread seal
Connection 2	metric cylindrical outer thread
Sealing form 2	24° inner cone
Design	Screw-in fitting
Construction	straight
Standard	DIN 2353 ISO 8434-1
Scope of supply	Socket with union nut and cutting ring
Material	Brass

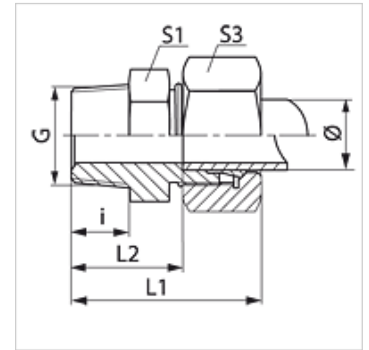

Note

Information about fitting, installation, pressure loads and permissible operating temperatures can be found in the technical information for pipe fittings.

Item

Identification	Series	Operating pressure	External pipe Ø (mm)	G	i (mm)	L1 (mm)	L2 (mm)	S1	S3
VR 04 LL MG	LL	PN 63	4	R 1/8" K	8	26	16,0	11	10
VR 06 LL MG	LL	PN 63	6	R 1/8" K	8	26	14,5	11	12
VR 08 LL 1/4 MG	LL	PN 63	8	R 1/4" K	13	33	21,5	17	14
VR 08 LL MG	LL	PN 63	8	R 1/8" K	8	28	16,5	12	14
VR 10 LL MG	LL	PN 63	10	R 1/4" K	12	32	20,5	14	17
VR 12 LL MG	LL	PN 63	12	R 1/4" K	12	32	20,0	17	19

Series: LL = Very light L = Light S = Heavy – PN = Nominal pressure PB = Max. operating pressure – Ø = External pipe diameter

Product versions

VRK	Screw-in fitting, Steel
VRK VA	Screw in fitting, Stainless steel