

XSA VA

Welded on fitting

Properties

Connection 1	Welded on socket for metric pipe
Connection 2	metric cylindrical outer thread
Sealing form 2	24° inner cone
Design	Welded on fitting
Construction	straight
Standard	DIN 2353 ISO 8434-1
Scope of supply	Socket (without union nut and cutting ring)
Material	Stainless steel

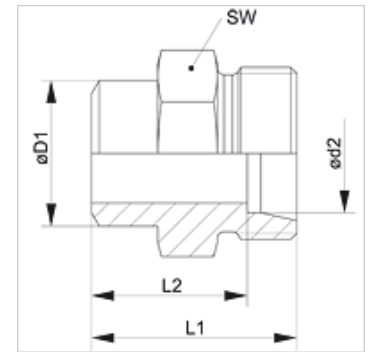

Note

Information about fitting, installation, pressure loads and permissible operating temperatures can be found in the technical information for pipe fittings.

Item

Identification	Series	Operating pressure	Ø d2 (mm)	Ø D1 (mm)	L1 (mm)	L2 (mm)	AF (mm)
XSA NW 04 HL VA	L	PN 315	6	10	21	14,0	14
XSA NW 06 HL VA	L	PN 315	8	12	23	16,0	14
XSA NW 08 HL VA	L	PN 315	10	14	25	18,0	17
XSA NW 10 HL VA	L	PN 315	12	16	25	18,0	19
XSA NW 13 HL VA	L	PN 315	15	19	29	22,0	22
XSA NW 16 HL VA	L	PN 315	18	22	31	23,5	27
XSA NW 20 HL VA	L	PN 160	22	27	36	28,5	32
XSA NW 25 HL VA	L	PN 160	28	32	38	30,5	41
XSA NW 32 HL VA	L	PN 160	35	40	43	32,5	46
XSA NW 40 HL VA	L	PN 160	42	46	46	35,0	55
XSA NW 03 HS VA	S	PN 630	6	11	26	19,0	14
XSA NW 04 HS VA	S	PN 630	8	13	28	21,0	17
XSA NW 06 HS VA	S	PN 630	10	15	30	22,5	19
XSA NW 08 HS VA	S	PN 630	12	17	32	24,5	22
XSA NW 10 HS VA	S	PN 630	14	19	35	27,0	24
XSA NW 13 HS VA	S	PN 400	16	21	35	26,6	27
XSA NW 16 HS VA	S	PN 400	20	26	40	29,5	32
XSA NW 20 HS VA	S	PN 400	25	31	44	32,0	41
XSA NW 25 HS VA	S	PN 400	30	36	49	35,5	46
XSA NW 32 HS VA	S	PN 315	38	44	54	38,0	55

Series: LL = Very light L = Light S = Heavy – PN = Nominal pressure PB = Max. operating pressure – Ø d2 = External pipe diameter

Product versions

XSA	Welded on fitting, Steel
SA VA	Welded on fitting, Stainless steel