

# KLR V

## Clamping ring for flared coupling parts

### Properties

<b>Design</b>	Clamping ring
<b>Material</b>	Steel
<b>Surface</b>	electro galvanised

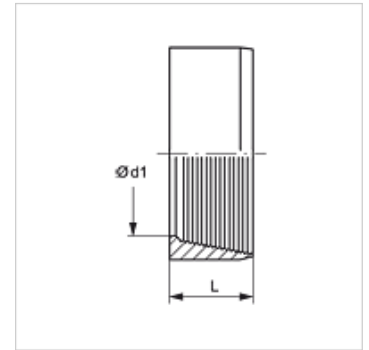

### Item

Identification	Series	Operating pressure	Ø d1 (mm)	L (mm)
KLR NW 04 L V	L	PN 315	6	3,8
KLR NW 06 L V	L	PN 315	8	3,8
KLR NW 08 L V	L	PN 315	10	3,8
KLR NW 10 L V	L	PN 315	12	3,8
KLR NW 13 L V	L	PN 315	15	4,5
KLR NW 16 L V	L	PN 315	18	4,5
KLR NW 20 L V	L	PN 160	22	5,0
KLR NW 25 L V	L	PN 160	28	5,5
KLR NW 32 L V	L	PN 160	25	7,0
KLR NW 40 L V	L	PN 160	42	7,0
KLR NW 04 S V	S	PN 630	8	4,5
KLR NW 06 S V	S	PN 630	10	4,5
KLR NW 08 S V	S	PN 630	12	4,5
KLR NW 10 S V	S	PN 630	14	6,5
KLR NW 13 S V	S	PN 400	16	6,5
KLR NW 16 S V	S	PN 400	20	9,0
KLR NW 20 S V	S	PN 400	25	10,0
KLR NW 25 S V	S	PN 400	30	10,0
KLR NW 32 S V	S	PN 315	38	13,5

Series: LL = Very light L = Light S = Heavy – PN = Nominal pressure PB = Max. operating pressure – Ø d1 = External pipe diameter